

# PROJET NOVA-TEMP® HT6103+

Factory-built CHIMNEY  
5", 6", 7", 8" & 10" dia.  
TYPE HT

## SUMMARY

### USA

OUR PRODUCTS LIVE UP TO OUR NAME, WARNING . . . . .	2
GENERAL INFORMATION, USA & CANADIAN APPLICATIONS . . . . .	2
KEEP YOUR CHIMNEY CLEAN, SIZING CHART . . . . .	3
GENERAL INSTALLATION NOTES . . . . .	4
STEP BY STEP INSTALLATIONS . . . . .	5
INTERIOR INSTALLATION WITH CATHEDRAL CEILING . . . . .	6
OFFSET INSTALLATION . . . . .	7-8
EXTERIOR INSTALLATION . . . . .	9-10
INTERIOR INSTALLATION ON A FURNACE & WATER HEATER . . . . .	19
SPECIALIZED COMPONENTS . . . . .	20
WARRANTY . . . . .	21

### CANADA

OUR PRODUCTS LIVE UP TO OUR NAME, WARNING . . . . .	2
GENERAL INFORMATION, USA & CANADIAN APPLICATIONS . . . . .	11
KEEP YOUR CHIMNEY CLEAN, SIZING CHART . . . . .	3
GENERAL INSTALLATION NOTES . . . . .	4
INTERIOR STRAIGHT INSTALLATION WITH MULTIPLE FLOOR . . . . .	12
INTERIOR INSTALLATION WITH CATHEDRAL CEILING . . . . .	14
OFFSET INSTALLATION . . . . .	15-16
EXTERIOR INSTALLATION . . . . .	17-18
INTERIOR INSTALLATION ON A FURNACE & WATER HEATER . . . . .	19
SPECIALIZED COMPONENTS . . . . .	20
WARRANTY . . . . .	21

## INSTALLATION

## AND

## OPERATION

## INSTRUCTIONS

**Read these instructions and keep them for future reference**

Listed: Warnock Hersey 9651  
Standard: CAN /ULC-S604  
UL-103HT  
CAN/ULC-S629 (6", 7", 8" only)



SECURITY CHIMNEYS INTERNATIONAL LTD  
2125 Monterey, Laval  
(Quebec) Canada H7L 3T6  
(450) 973-9999

P/N 506128-14 Rev. M 01/2012

PIHT6103+ REV. 14 06/2014

# OUR PRODUCTS LIVE UP TO OUR NAME

## CONGRATULATIONS!

You have just purchased one of the safest chimneys in North America. Designed with care, using the latest technology, it has been manufactured in accordance with **ISO** International Standards of Quality. The chimney is easy to install and all parts of the system are built to fit perfectly with each other. If you're handy, know how to use a few simple tools and have some basic carpentry skills, you can install your PROJET® **HT6103+** chimney yourself over one weekend. Or you can hire a professional to do the job, which will take a few hours.

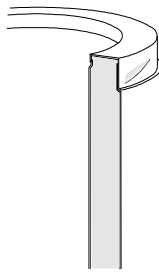

**WARNING**

**A MAJOR CAUSE OF CHIMNEY-RELATED FIRES IS FAILURE TO MAINTAIN REQUIRED CLEARANCES (AIR SPACES) TO COMBUSTIBLE MATERIALS. IT IS OF UTMOST IMPORTANCE THAT THIS CHIMNEY BE INSTALLED ONLY IN ACCORDANCE WITH THESE INSTRUCTIONS.**

## RECOMMENDATIONS

### Clearance

The clearances stated in this guide are minimum requirements: if more space is available, use it. Minimum clearances mean leaving unobstructed air space. Do not fill these spaces with any material whatsoever, especially not insulating material. If you insulate your attic later, be sure to maintain the necessary clearance.

### Inspection

Contact local building or fire officials about restrictions, installation inspection and permit that may be required in your area.

### Replacement Parts

If a component of your chimney system is damaged it must be replaced by an identical one from Security Chimneys.

## NOT ALL WOOD IS CREATED EQUAL

Some types of wood have greater energy potential than others. Some logs will give you a hot, crackling fire, others will burn longer and more evenly. Choose the type of flame you prefer. The following table shows how different types of wood burn.

Wood Type	Ability To Create Long Lasting Coals	Sparks	Fragrance	Heating Qualities
Black Locust	Excellent	Very Few	Slight	Excellent
Maple	Excellent	Few	Good	Excellent
Oak	Excellent	Few	Fair	Excellent
Hickory	Excellent	Moderate	Slight	Excellent
Beech	Good	Few	Slight	Excellent
Cherry	Excellent	Few	Excellent	Good
Apple	Excellent	Few	Excellent	Good
Elm	Good	Very Few	Fair	Good
Ash	Good	Few	Slight	Good
Birch	Good	Moderate	Slight	Good
Hemlock	Low	Many	Good	Fair
Pine	Poor	Moderate	Good	Fair
Cedar	Poor	Many	Good	Fair

Table 1

## BURNING SMART

How you burn wood in your stove or fireplace directly affects the formation of creosote. Smaller, hotter fires are better than large, smouldering ones. Fast, effective start ups are important, as is the moisture content of the wood. Ideally, you should use seasoned wood with a moisture content of 20-25%. If your wood is not completely seasoned, use more dry kindling and paper first to warm the chimney to a temperature of at least 300°F. A surface thermometer is an excellent investment. Properly seasoned wood can produce 8,600 BTUs per pound.

## APPLICATIONS

### WOOD AND COAL STOVES

The PROJET HT6103+ chimney has been designed for use with wood, gas, oil and coal in residential, commercial and industrial applications. Specially developed for use with controlled-combustion stove and wood burning fireplace. It is listed to UL-103HT standards, 2100°F for USA in diameters of 5, 6, 7, 8 and 10 inches.

**In Canada, the PROJET HT6103+ chimney has been listed to ULC-S629, 2100 F in diameter 6, 7 and 8 inches for wood/coal application. Note that for interior enclosed installation, premium shield are required around the chimney. Refer to specific Canadian installation section for proper installation.**

**In Canada, the PROJET HT6103+ chimney is also designed for use with gas or oil fired heating appliances such as furnace, hot water heaters and other appliances, as per ULC-S604 standards in diameter 5 to 10 inches. In these types of installations, no premium shields are required even where the chimney is enclosed.**

If you are planning to install a wood stove, we recommend that you:

1. Choose a stove that bears the label of a testing laboratory (such as UL, CSA, WH, ULC or ICBO).
2. Choose the right size stove. Do not buy one larger than you need.
3. Connect only one appliance to a chimney.
4. Never overfire your stove. If any part of the stove or stove pipe is glowing red, then you are overfiring. Immediately close the stove's dampers until the system cools. The high temperature caused by overfiring can permanently damage the stove and stove pipe and may overheat nearby combustible walls and furniture.
5. Install the stove and stove pipe as described in the installation instructions accompanying the stove. Be certain to maintain the required clearances to combustible construction.
6. Keep your flue gases between 300°F and 500°F. This will maximize efficiency while minimizing condensation and creosote formation. Do not fill your stove with wood and allow it to smoulder for 8 to 10 hours. This condition produces large amounts of creosote in the chimney.
7. Do not burn sea driftwood or treated wood. These combustibles are highly corrosive to all types of stainless steel.

### FACTORY BUILT FIREPLACE

The HT6103+ chimney in Canada is also suitable for use with closed or opened fireplaces such as the BIS fireplaces, and other fireplaces certified for use with the HT6103+ chimney.

When doing so please refer to the fireplace installation instruction to install the chimney.

**Note that the premium shields are not required for factory-built fireplace installation, including interior chase.**

# KEEP YOUR CHIMNEY CLEAN

## CHIMNEY OPERATION AND MAINTENANCE

Wood stoves can quickly create large deposits of creosote in the chimney. Some wood stoves can create enough creosote in two weeks to cause a chimney fire. When using a wood stove, we recommend that you:

1. Initially inspect the chimney system weekly. From this, you will learn how often it will be necessary to clean your chimney.
2. The chimney should be inspected at least once every 2 months during the heating season to determine if a creosote or soot build-up has occurred: if creosote or soot has accumulated, it should be removed to reduce the risk of chimney fire.
3. Have your chimney cleaned by a qualified chimney sweep. If you want to clean your chimney yourself: clean your chimney using plastic, wood or stainless steel brushes. Do not use a brush that will scratch the stainless steel interior of your chimney.
4. Do not expect chemical chimney cleaners to keep your chimney clean. Their use does not negate the necessity of periodically inspecting and cleaning your chimney.

## CHIMNEY FIRES

If you are having a chimney fire, follow these steps:

1. Close all heater doors and combustion air controls. For fireplaces, block the fireplace opening with a non-combustible material (such as an asbestos or steel sheet).
2. Alert your family to the possible danger.
3. If you require assistance, alert your fire department.
4. If possible, use a dry chemical fire extinguisher, baking soda or sand to control the fire. Do not use water as it may cause a dangerous steam explosion.
5. Watch for smoldering or fire on combustibles next to the stove, stove pipe and chimney. Check outside to ensure that sparks and hot embers coming out of the chimney are not igniting the roof.
6. Do not use the stove again until your chimney and stove pipe have been inspected by a qualified chimney sweep or Fire Department Inspector.

**The HT6103+ chimney has been designed to withstand the intense heat of a chimney fire. Nevertheless chimney fires are dangerous and should be prevented.**

### BEFORE HIRING A CHIMNEY SWEEP

1. Does the company or individual have adequate liability insurance in case of damage?
2. How long has the company been in business?
3. Does the company offer current references?
4. Is the company involved in any unresolved disputes?

# SIZING CHART

CHIMNEY-SIZE	5"	6"	7"	8"	10"
OUTSIDE-DIAMETER	7"	8"	9"	10"	12"
<b>HOLE-DIMENSION-REQUIRED</b>					
Base-support (BS2)	12-1/8"	12-1/8"	14-3/8"	14-3/8"	--
Cathedral support (CSC)	--	12-1/8"	14-3/8"	14-3/8"	--
Square support (CSBC)	--	12-1/8"	14-3/8"	14-3/8"	14-3/8"
Finish support (FCSC)	--	12-1/8"	14-3/8"	14-3/8"	--
Firestop (FS+)	11-3/8"	12-3/8"	13-3/8"	14-3/8"	16-3/8"
<b>MAX. LENGTH HEIGHT SUPPORTED **</b>					
Base support (BS2)	--	32'	32'	32'	32'
Tee support (WS/WASA)	63'	63'	55'	48'	39'
Roof support (PST+)	42'	34'	27'	24'	20'
Radiation Shield Connector Support (RSSR)	--	30'	24'	21'	--
Cathedral support (CSC)	--	75'	65'	59'	--
Square support (CSBC)	--	60'	50'	45'	35'
Adj. square support (PPS)	27'	22'	--	--	--
Finish support (FCSC)	--	75'	65'	59'	--
Offset support (PSO+)	--	28'	24'	20'	14'
Insulated tee (ITS+) *	63'	63'	55'	50'	50'
<b>CLEARANCE TO COMBUSTIBLES</b>	2"	2"	2"	2"	2"

Table 2

\* When installed on a concrete footing.

\*\* NOTE: If greater height is required, use additional roof supports at intervals not exceeding 30'

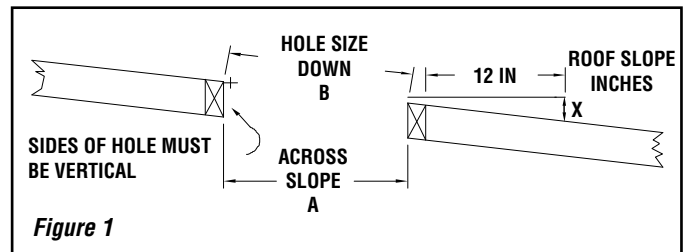

CHIMNEY SIZE	5"	6"	7"	8"	10"					
ROOF SLOPE	<b>HOLE SIZE</b>									
x/12	A	B	A	B	A	B	A	B	A	B
0	11-3/8"	11-3/8"	12-3/8"	12-3/8"	13-3/8"	13-3/8"	14-3/8"	14-3/8"	16-3/8"	16-3/8"
2/12	11-3/8"	11-1/2"	12-3/8"	12-1/2"	13-3/8"	13-1/2"	14-3/8"	14-9/16"	16-3/8"	16-19/32"
4/12	11-3/8"	12	12-3/8"	13	13-3/8"	14-3/32"	14-3/8"	15-5/32"	16-3/8"	17-1/4"
6/12	11-3/8"	12-11/16"	12-3/8"	13-13/16"	13-3/8"	14-15/16"	14-3/8"	16-3/32"	16-3/8"	18-5/16"
8/12	11-3/8"	13-11/16"	12-3/8"	14-7/8"	13-3/8"	16-1/16"	14-3/8"	17-1/4"	16-3/8"	19-11/16"
10/12	11-3/8"	14-13/16"	12-3/8"	16-1/8"	13-3/8"	17-7/16"	14-3/8"	18-23/32"	16-3/8"	21-5/16"
12/12	11-3/8"	16-1/16"	12-3/8"	17-1/2"	13-3/8"	18-29/32"	14-3/8"	20-11/32"	16-3/8"	23-5/32"

Table 3 - Refer to Figure 1

# 1

## GENERAL INSTALLATION NOTES (USA)

### INSTALLATION NOTES (USA)

- The chimney is intended for use with solid, liquid and gaseous fuel burning appliances.  
Allowable flue gas temperature:  
Maximum continuous 540°C (1000° F)  
Brief forced firing 760°C (1400°F)  
Tested to 1150°C (2100°F) - 10 minutes
- The maximum height of chimney supported by the various Oliver Macleod® supports are outlined on **page 3**.
- The supports described in this booklet should only be used with Oliver Macleod model PROJET HT6103+, 5", 6", 7", 8" and 10" factory built chimneys.
- Size the chimney in accordance with the appliance manufacturer's instructions.
- When a firestop (FS+ or AFRS) need to be installed, it is important to follow the cutting dimensions for the floor openings prescribed in this manual. This way, the holes left by the folded positioning tab of the firestop will be blocked by the ceiling.
- A chimney servicing a fireplace or an incinerator shall not serve any other appliance.
- The chimney shall extend at least 3 ft above its point of contact with the roof and at least 2 ft higher than any wall, roof or adjacent building within 10 ft of it.
- The maximum height of unguided chimney above the roof is 5 ft.
- The clearance between single wall pipe and unprotected combustible material must not be less than 18" (see national building code and NFPA 211) except: The distance between the vertical stove pipe and the ceiling may be less than 18" and will be established by the finish support.
- Portions of the chimney which may extend through accessible spaces shall be enclosed in all cases to avoid personal contact with the chimney and damage to the chimney. Except for installation in single and two-story family dwellings, the enclosure must have a fire resistance rating equal to or greater than that of the floor or roof assemblies through which they pass.
- Do not fill the 2" space around the chimney with insulation or any other material. Insulation placed in this area could cause adjacent combustibles to overheat.
- Self tapping screws are not required, but may be used to reinforce the connection and avoid accidental unlocking of chimney lengths.



### WARNING

The clearance between the chimney and combustible material must not be less than 2", except where established by the support. Do not fill this area with insulation.

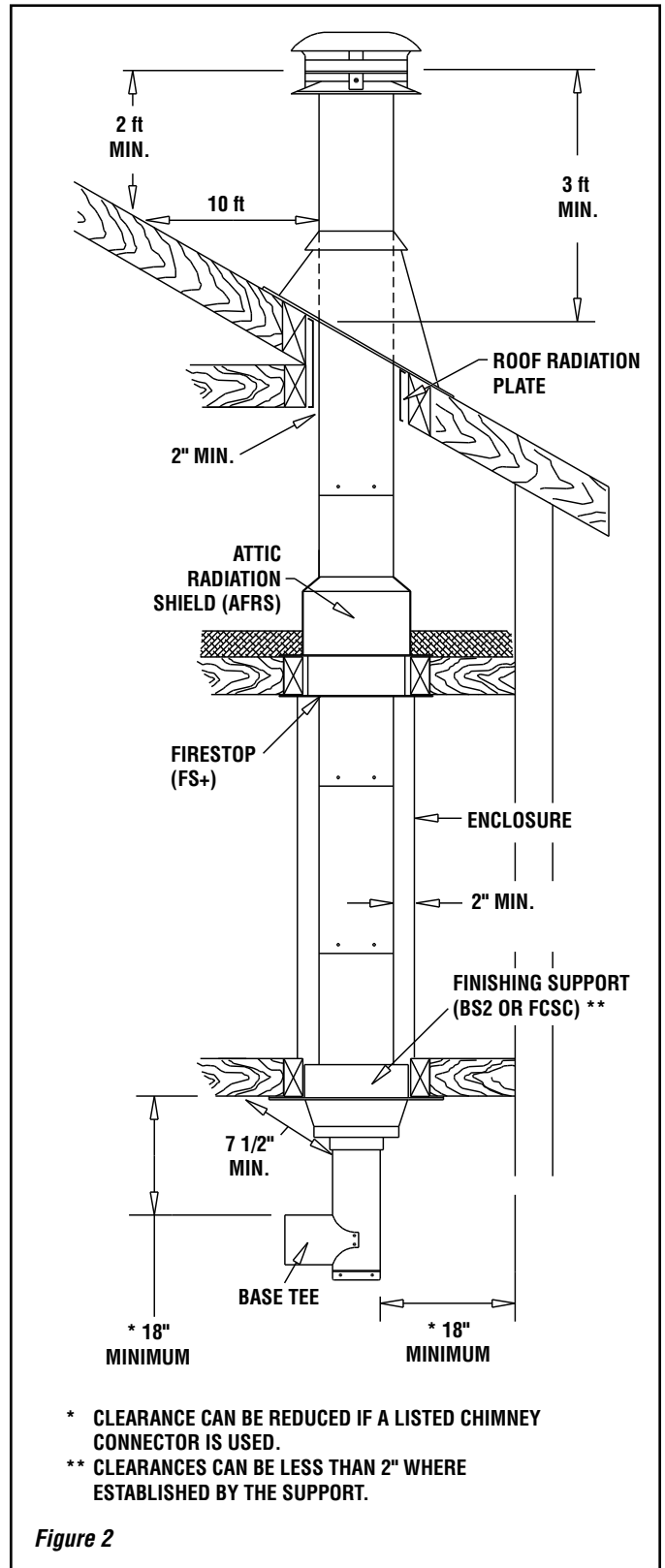

# 2

## STEP BY STEP INSTALLATIONS (USA)

**Step 1.** Locate the chimney in a convenient place as near as possible to the appliance outlet.

**Step 2.** Cut and frame the holes in the floor, ceiling and roof where the chimney will pass.

**Note:** It is important to follow the cutting dimensions for the floor openings prescribed in this manual. This way, the holes left by the folded positioning tab of the firestop (FS+ or AFRS) will be blocked by the ceiling.

CHIMNEY SIZE	HOLE SIZE	
	FINISH SUPPORT (FCSC) or (BS2)	RADIATION SHIELD* & ROOF
5"	12-1/8" x 12-1/8"	11-3/8" x 11-3/8"
6"	12-1/8" x 12-1/8"	12-3/8" x 12-3/8"
7"	14-3/8" x 14-3/8"	13-3/8" x 13-3/8"
8"	14-3/8" x 14-3/8"	14-3/8" x 14-3/8"
10"	---	16-3/8" x 16-3/8"

**Table 4** \* For sloping roofs see size table 3 on page 3

**Step 3.** From below push the finish support into the framed hole. Nail the support to the framed box using (12) 3" spiral nails (see figure 3).

**Step 4.** Put this first chimney length in the support. Turn it clockwise to lock it in place (see figure 4).

**Note:** the male coupling must be on top.

**Step 5.** From below, install a firestop plate (FS+) in each floor through which the chimney passes.

**Step 6.** Stack the next chimney length on the first length. Be sure that the male and female threads are not in line when putting the lengths together. Turn the chimney clockwise to lock it in place. You may add a 1/2" stainless steel self tapping screw to prevent accidental unlocking. Continue until the required chimney height is reached.

**Step 7.** At the attic level, install a firestop plate (FS+), from below and an attic radiation shield (AFRS) from above (see figure 5).

Install the roof radiation shield in the roof joists. This shield consists of four metal plates supplied with the roof flashing. Nail one plate to each side of the joist using (2) - 2 1/2" nails.

### Step 8. ROOF FLASHING INSTALLATION

Put the roof flashing in place. Seal the joint between the roof and the flashing with roofing pitch.

For sloping roofs, place the flashing under the upper shingles and on top of the lower shingles.

Nail the flashing to the roof using roofing nails.

Place the storm collar over the chimney and the flashing. Tighten it with the bolt supplied making sure the joint is properly caulked (see figure 6).

**Step 9.** Fit the rain cap to the top of the chimney. Turn it clockwise to lock it in place.

**Step 10.** Wash the roof flashing with a solvent or vinegar, then paint it with rust proof paint, for longer lasting.

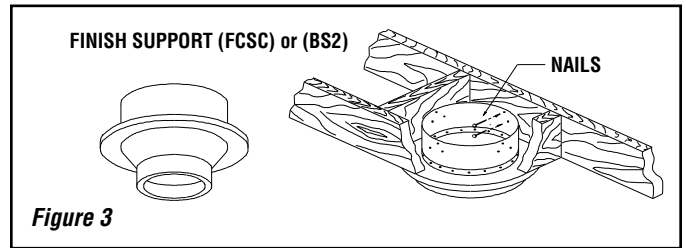

Figure 3

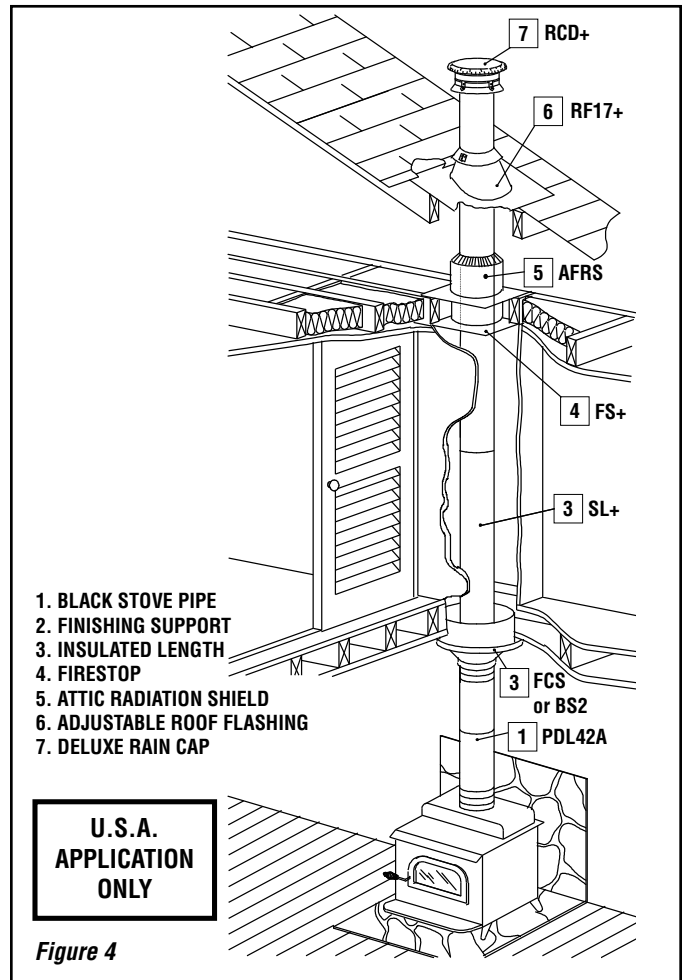

Figure 4

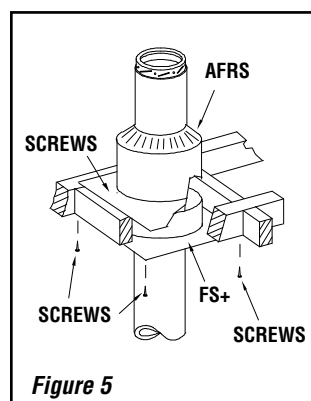

Figure 5

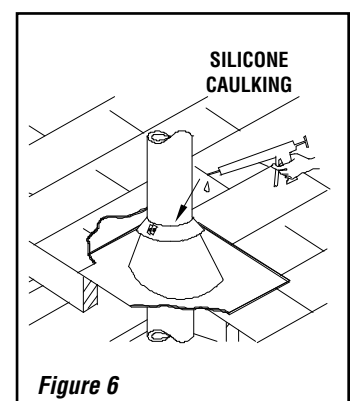

Figure 6

# 2

## INTERIOR INSTALLATION WITH CATHEDRAL CEILING (USA)

### B - SQUARE SUPPORT (CSBC) AND ADJUSTABLE SQUARE SUPPORT (PPS)

This support is designed to be used in rooms with cathedral ceilings (no attic space between the ceiling and the roof). If the support is used as a regular floor support, follow the instructions for the finish support FCS on [page 12](#).

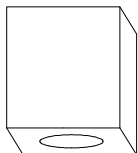

CSBC

The adjustable square support requires an opening of 12" x 12" up to 12" x 22-1/2" in the ceiling (see [Figure 9](#)).

### SUPPORT EXTENSION (CSBX) (For square support only)

Steep pitched cathedral ceilings may require the use of a square support extension (CSBX). This piece fits down inside the square support and can be adjusted to increase the support's length by up to 16".

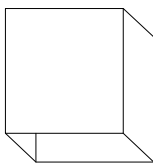

CSBX

The extension is attached to the support using the eight metal screws provided. Be sure there is at least a 2" overlap where the extension joins the support.

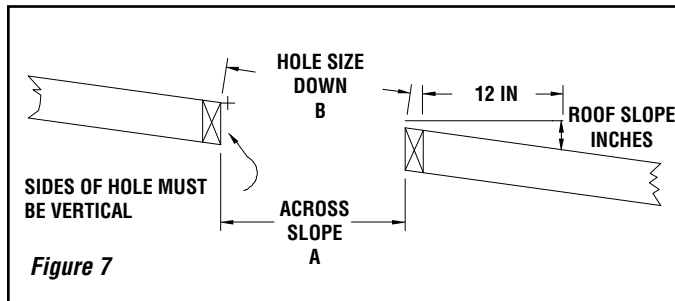

Figure 7

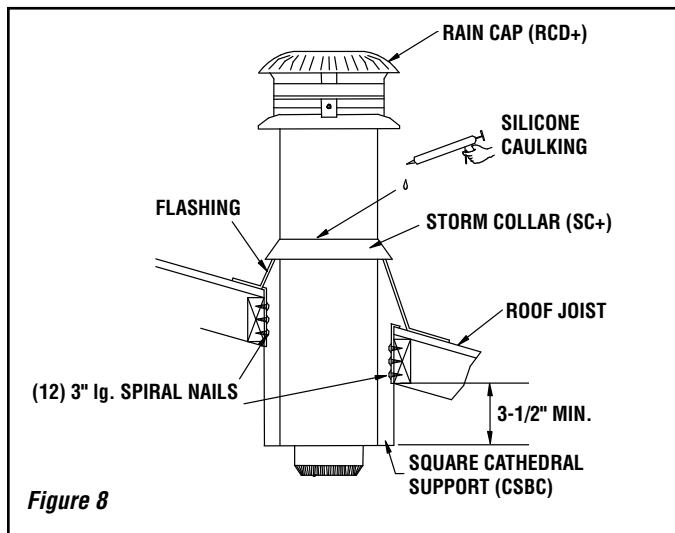

Figure 8

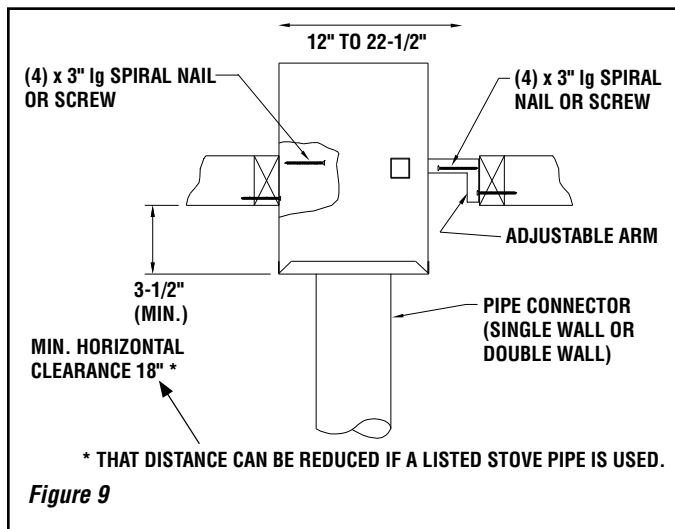

Figure 9



# 3 OFFSET DEVIATION (USA)

## OFFSET CHIMNEY

If it is necessary to offset the chimney in order for it to pass through an upstairs cupboard or to clear a joist, do this by using 15° or 30° insulated elbows. A maximum of two offsets (4 elbows in all) is allowed in a chimney. The chimney must not be inclined more than 30° from vertical.

The minimum chimney height when using 15° offsets is 10'.

The minimum chimney height when using 30° offsets is 15'.

The maximum length of unsupported offset chimney is 6'. If the offset chimney is longer than 6', then it must be supported at 6' intervals using an offset support (PSO+) or wall band (WB).

## INSTALLATION INSTRUCTIONS

Install the required support and the chimney as described in the support's installation instructions. When you reach the height at which the elbow will be installed, proceed as follows:

- Step 1.** Install the insulated offset elbow on the vertical chimney length. Turn it in the required direction and fasten it to the chimney with the (4)-1/2" metal screws provided.
- Step 2.** Place the required offset chimney length (see chart below) on the elbow. Turn it clockwise to lock it in place.
- Step 3.** Use another elbow to turn the chimney vertically. Again secure the elbow to the chimney length using the (4)-1/2" metal screws.
- Step 4.** Install the remaining chimney as described in the instructions for the roof support (*figure 13A, page 8*).

## INSTALLATION CALCULATIONS

Determine the offset required in view of the obstacles that must be avoided (see *Figure 11*). Refer to *table 5* to determine the elbows required as well as the insulated length needed.

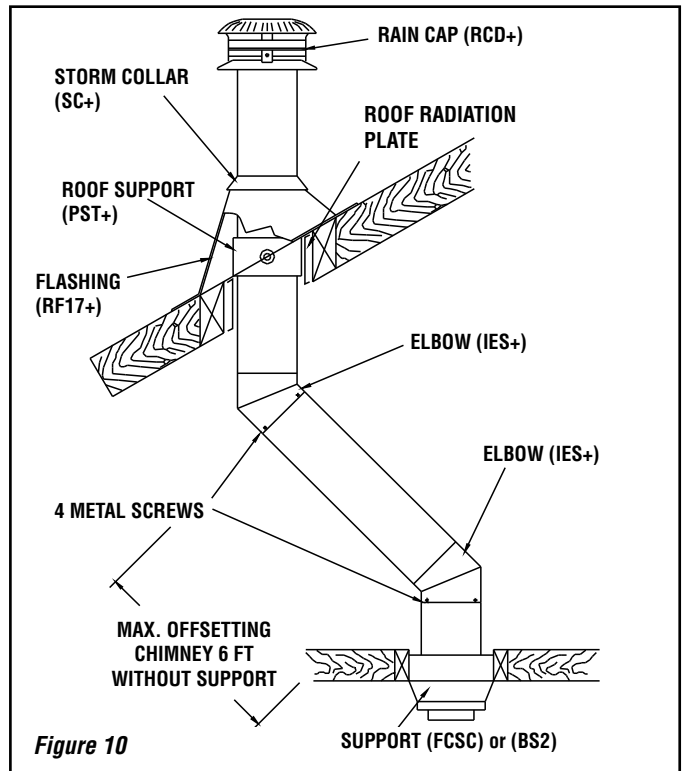

Figure 10

**⚠ WARNING**

**A support must always be installed right above each offset (two elbows) to support the chimney above the offset.**

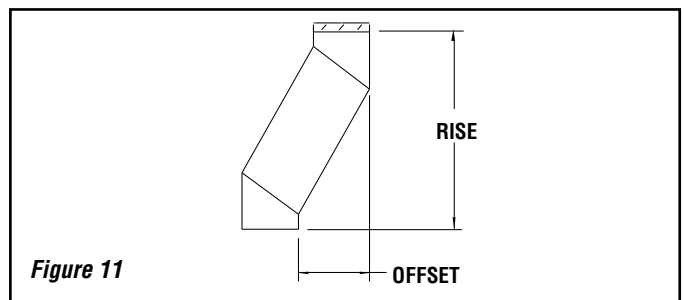

Figure 11

## OFFSET & RISE CHART MODEL HT6103+ (5" @ 10")

ANGLE	DIA.	INCHES	ONE LENGTH BETWEEN ELBOWS						TWO LENGTHS BETWEEN ELBOWS					
			8	12	18	24	36	48	8 & 48	12 & 48	18 & 48	24 & 48	36 & 48	48 & 48
15°	5" @ 10"	Offset	3-5/16	4-5/16	5-7/8	7-7/16	10-1/2	13-5/8	15-3/8	16-7/16	18	19-1/2	22-5/8	25-3/4
		Rise	15-11/16	19-9/16	25-3/8	31-3/16	42-3/4	54-3/8	60-15/16	64-13/16	70-9/16	76-3/8	87	99-9/16
30°	5" @ 10"	Offset	7-7/16	9-7/16	12-7/16	15-7/16	21-7/16	27-7/16	30-13/16	32-13/16	35-13/16	38-13/16	44-13/16	50-13/16
		Rise	20	23-1/2	28-11/16	33-7/8	44-1/4	54-11/16	60-9/16	64	69-1/4	74-7/16	84-13/16	95-1/4

Table 5

# 3

## OFFSET INSTALLATION (CONT'D) (USA)

### ROOF SUPPORT (PST+)

The roof support has three possible uses:

It may be used to support a chimney from the roof. It adjusts to any roof pitch.

It may be used on a floor, ceiling or roof above an offset to support the chimney above the offset.

It may be used on a floor, ceiling or roof as a supplementary support when the chimney height exceeds that of the primary support. (See *maximum length height supported*, **page 3**).

### INSTALLATION INSTRUCTIONS

With the chimney extending through the hole in the roof, ceiling or floor and the radiation shield in place, proceed as follows (Refer to **figure 13B** for visual references):

- Step 1.** Assemble the support collar to fit your chimney diameter, as described on the instruction sheet supplied with the support.
- Step 2.** Slip the support down over the stainless steel chimney until its brackets rest on the roof or floor. Tighten the collar around the chimney, then secure it by screwing the four 1/2" metal screws (supplied) through the holes located on each side of the collar bolts and into the chimney (**figure 13a**).
- Step 3.** Center the chimney and nail or screw the support to the roof or floor using (8) - 2-1/2" nails or (8) N°8 - 1-1/4" wood screws. (**figure 13a**).
- Step 4.** Install the remaining chimney lengths, until the required chimney height is reached.
- Step 5.** Install the roof radiation shields in the roof joists. These shields consist of four metal plates. Nail one plate to each side of the joist using (2) 2-1/2" nails.
- Step 6.** Put the roof flashing in place. Seal the joint between the roof and the flashing with roofing pitch. For sloping roofs, place the flashing under the upper shingles and on top of the lower shingles. Nail the flashing to the roof using roofing nails. Place the storm collar over the chimney and push down. Caulk the joint between the chimney and collar with silicone caulking.
- Step 7.** Fit the rain cap to the top of the chimney. Turn it clockwise to lock it in place.
- Step 8.** Wash the roof flashing with a solvent or vinegar. Then, paint it with rust proof paint.

### OFFSET SUPPORT (PSO+)

When a chimney offset is used to traverse a wall, this support may be used on the wall to support the chimney. The height of chimney supported is shown in supported height **page 3**.

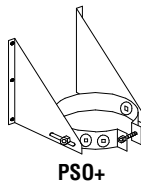

### INSTALLATION INSTRUCTIONS

Install the chimney according to the fireplace installation instructions. Install the support as follows (**figure 14**):

- Step 1.** Assemble the support collar to fit your chimney diameter as described on the installation sheet supplied with the support.
- Step 2.** Slip the support down over the chimney to a convenient location. Be sure that the support attaches to a solid wall and not merely to dry wall or aluminium siding.
- Step 3.** Tighten the collar around the chimney. Then, secure it by screwing four 1/2" metal screws (supplied) through the holes located on each side of the collar bolts and into the chimney.
- Step 4.** Attach the support brackets to the wall using (8) 3" nails or (8) N°10 x 1-1/4" wood screws.
- Step 5.** Continue installing the chimney according to the fireplace installation instructions.

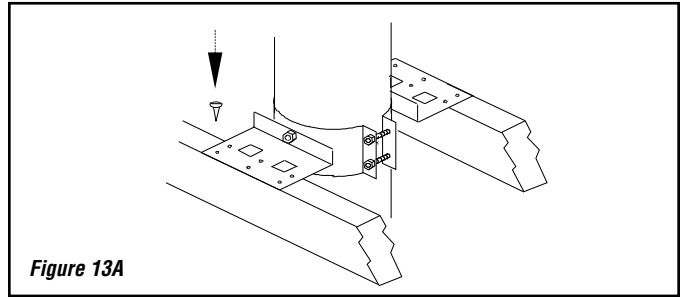

Figure 13A

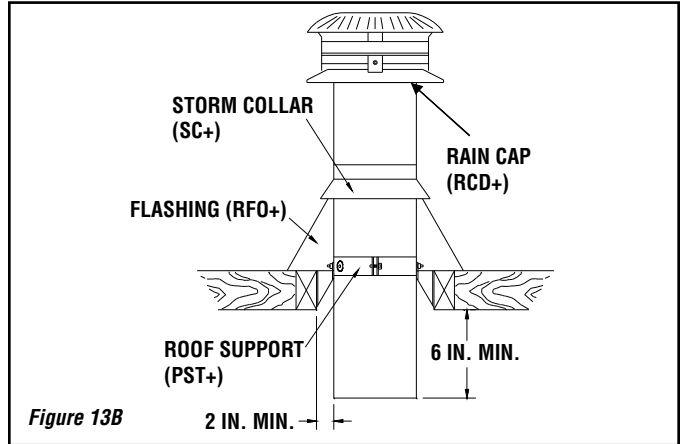

Figure 13B

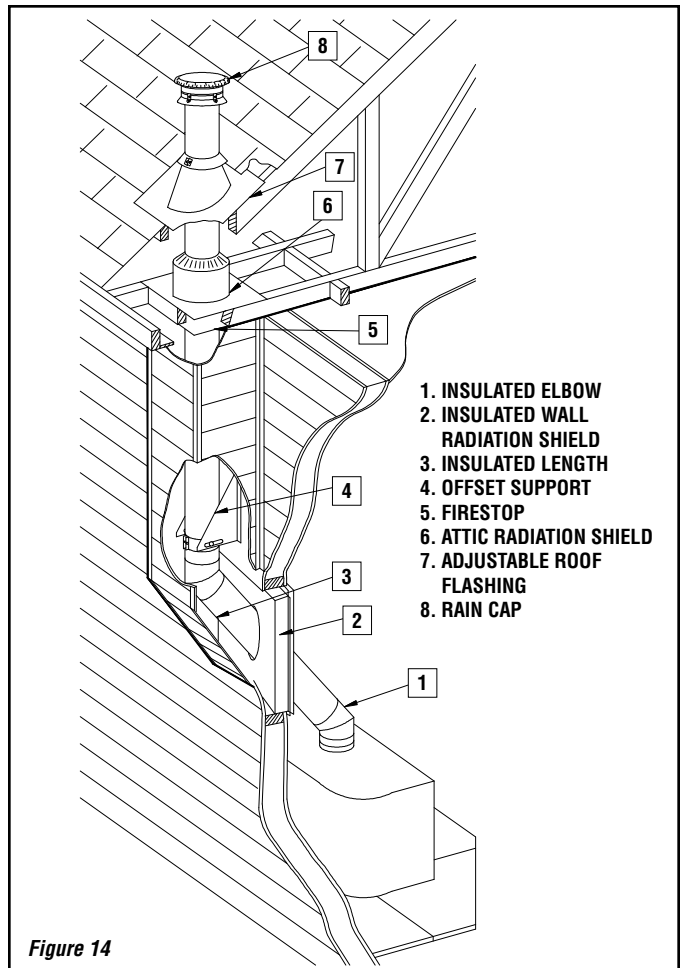

Figure 14



# 4

## EXTERIOR INSTALLATION (USA)

### TEE & WALL SUPPORT

Two supports are available, an adjustable with collar (AWS) and a non-adjustable with coupling (WS/WSA).

#### INSTALLATION NOTES

If possible, install an interior chimney as it will provide better performance than an exterior chimney. In areas with continuous temperatures below -18°C (0°F), the use of an exterior chimney may result in operating problems such as poor draft, excessive condensation of combustion products and rapid accumulation of creosote when connected to a wood burning appliance. If you do install an exterior chimney, we recommend that you enclose it using an insulated enclosure.

1. The chimney may be enclosed or unenclosed. Maintain 2" clearance to combustible materials. Do not fill the 2" space around the chimney with insulation or any other material.
2. A wall band must be used to secure the chimney to the wall. Maximum distance between wall bands is 8 feet.
3. The minimum length of chimney extending past the inside wall is 5 inches.
4. The maximum length of chimney extending past the inside wall is 24 inches.
5. The distance between the stove pipe and a parallel combustible wall or ceiling must not be less than 18". The distance between the horizontal stove pipe and the unshielded vertical wall through which it passes must not be less than 7 inches.
6. If an exterior installation is to be enclosed, allow for access to base of tee to facilitate required cleaning.
7. The minimum distance between the bottom of the support and any horizontal combustible (including the ground) is 6". This distance can be reduced to 2 inches by using an insulated tee cap (IC) in conjunction with a (AWS) wall support.
8. The adjustable support (AWS) may only be installed with an insulated tee cap (IC).

#### INSTALLATION INSTRUCTIONS STEPS

- Step 1.** Determine where the chimney will pass through the wall.
- For concrete walls cut a hole slightly larger than the chimney.
  - For combustible walls cut and frame a hole 4" larger than the chimney, midway between the wall studs (see table below for sizing).

Normally wall studs are placed at 16" centers. With the hole midway between them, the support will fasten to these studs and thus ensure a strong attachment to the wall (see *figure 16*).

CHIMNEY SIZE	HOLE SIZE	
	COMBUSTIBLE	CONCRETE
5"	11-3/8" x 11-3/8"	7-3/4"
6"	12-3/8" x 12-3/8"	8-3/4"
7"	13-3/8" x 13-3/8"	9-3/4"
8"	14-3/8" x 14-3/8"	10-3/4"
10"	16-3/8" x 16-3/8"	12-3/4"

*Table 6*

- Step 2.** Wood walls: from outside, put the square wall thimble (WRS+) in the hole. Nail in place using (4) 2" nails or 1" screws. This wall thimble is adjustable from 7" to 12". From inside, wrap the insulation pad around the tube of the square wall thimble previously installed. Place the metal sheet around the insulation pad and close it by joining the staples at each end of the metal sheet together. Make sure the gap is completely filled in from inside to outside (cut insulation pad to proper length).

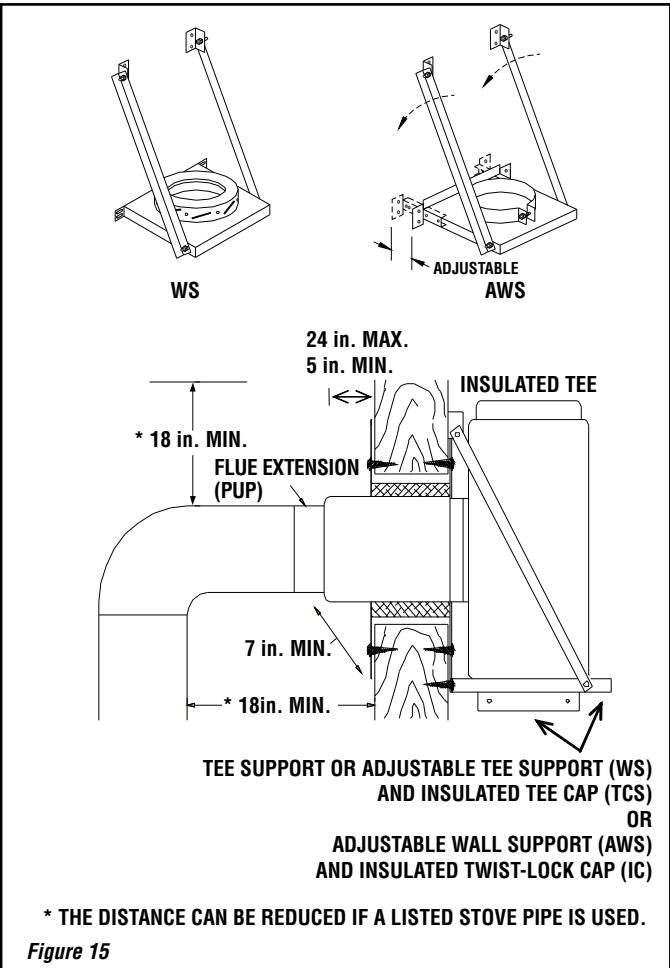

Figure 15

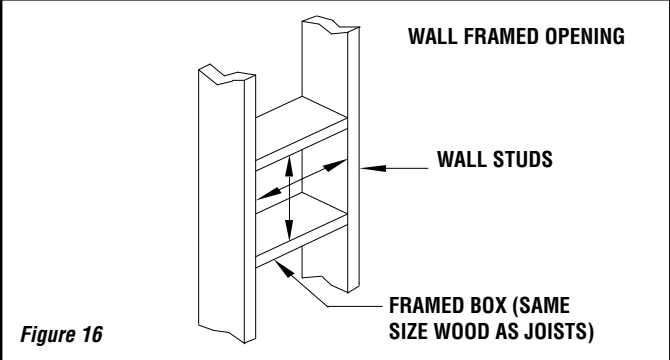

Figure 16

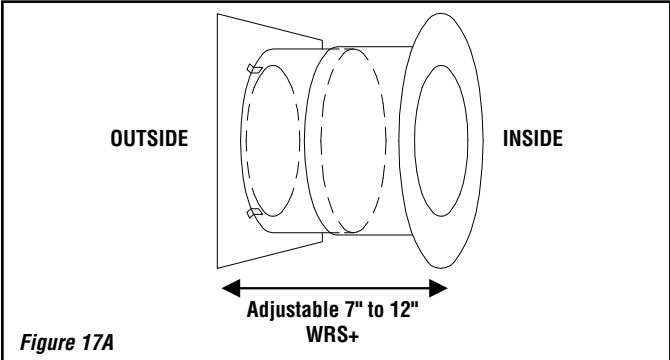

Figure 17A

NOTE: DIAGRAMS & ILLUSTRATIONS ARE NOT TO SCALE.

# 4

## EXTERIOR INSTALLATION (CONT'D) (USA)

Slide the large wall shield over the small wall shield. Using a level make sure that the hole for the chimney to pass through is horizontal. Screw the inner thimble in place with the provided screws (see **figure 17B**).

NOTE: The cavity surrounding the wall thimble must be filled with type R-20 insulation (see **figure 17B**).

**Step 3.** Attach the clean-out cap to the support's flue extension using the three metal screws provided. Make sure that the screws have pierced through the flue extension. The cap is in the box with the insulated tee. If an insulated tee cap is used, twist lock the tee cap to the tee (adjustable support AWS only).

**Step 4.** The minimum length of insulated chimney required to pass through the wall will be thickness plus 7". The insulated chimney must extend at least 5" into the room beyond the finished wall. Insert this chimney length in the side entry of the insulated tee. Turn it clockwise to lock it in place. Seal this joint by wrapping it with the aluminium tape supplied with the tee. Mount the insulated tee on the support so that the chimney length which will go through the wall is perpendicular to the side of the support that will fasten to the wall.

**Step 5.** This step will require 2 people: (See **figure 19**). Insert the chimney length of this tee-support assembly into the hole in the wall. Using a level, ensure the tee is vertical, then attach the support to the wall using (8) N°. 10 x 1 - 1/4" wood screws or 4" spiral nails.

NOTE: To provide sufficient strength, the nails must be driven into the wall studs. For concrete walls, the support should be attached using (8) 1/4" x 2" lag bolts.

**Step 6.** Attach the flue extension to the horizontal chimney length using the three metal screws provided.

**Step 7.** Stack a chimney length on top of the tee. Turn it clockwise to lock it in place. Continue until the required chimney height is reached. NOTE: At 8' intervals, attach the chimney to the wall using a wall band (WB).

**Step 8.** If the chimney passes through the roof, cut a hole large enough to provide 2" clearance between the chimney and the roof. For pitch roof, see chart on **page 3**. Install the roof radiation shield in the roof joist.

To continue, SEE ROOF FLASHING INSTALLATION, on **page 5**.

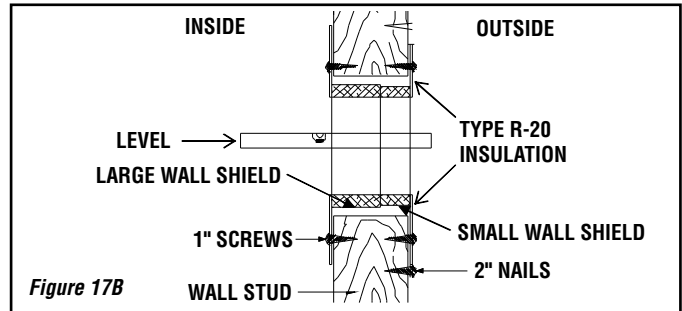

Figure 17B

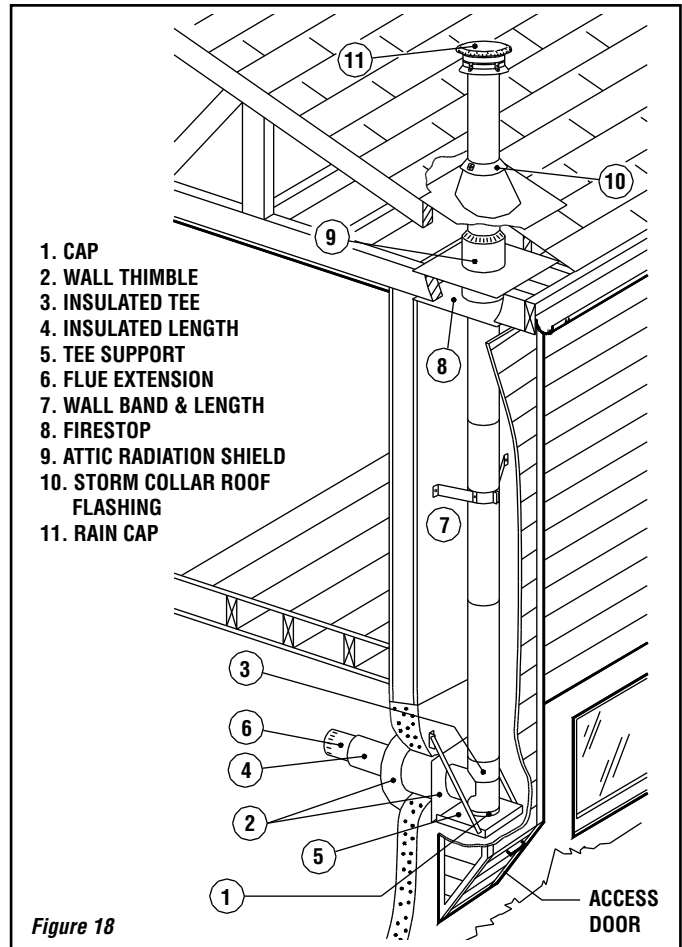

Figure 18

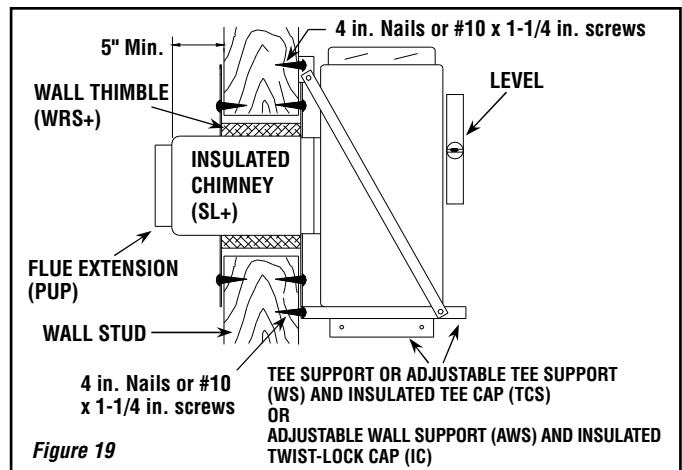

Figure 19

# 1

## GENERAL INSTALLATION NOTES (CANADA)

### INSTALLATION NOTES

- The chimney is intended for use with solid (6", 7", 8" dia. only) or liquid and gaseous fuel burning appliances. (all diameters)  
Allowable flue gas temperature:  
Maximum continuous 540°C (1000°F)  
Brief forced firing 760°C (1400°F)  
Tested to 1150°C (2100°F) - 30 minutes
- On wood or coal stove application and in area where the chimney is completely enclosed, it is required to install Premium shields (telescopic or flexible) around the chimney and a Radiation shield connector at the ceiling level.**  
**For venting of gas or oil burning appliances Premium shields are not required even where the chimney is enclosed.**  
**For factory-built wood burning fireplaces, Premium shields are usually not required, please follow fireplace installation instruction.**
- The maximum height of chimney supported by the various Oliver Macleod® supports are outlined on **page 3**.
- The supports described in this booklet should only be used with Oliver Macleod model HT6103+, 5", 6", 7", 8" and 10" factory built chimneys.
- Size the chimney in accordance with the appliance manufacturer's instructions.
- When a firestop (FS+, RCSP or AFRS) need to be installed, it is important to follow the cutting dimensions for the floor openings prescribed in this manual. This way, the holes left by the folded positioning tab of the firestop will be blocked by the ceiling.
- A chimney servicing a fireplace or an incinerator shall not serve any other appliance.
- The chimney shall extend at least 3 ft above its point of contact with the roof and at least 2 ft higher than any wall, roof or adjacent building within 10 ft of it.
- The maximum height of unguided chimney above the roof is 5 ft.
- The clearance between single wall pipe and unprotected combustible material must not be less than 18" (see national building code and NFPA 211) except: The distance between the vertical stove pipe and the ceiling may be less than 18" and will be established by the finish support.
- Portions of the chimney which may extend through accessible spaces shall be enclosed in all cases to avoid personal contact with the chimney and damage to the chimney. When doing so on woodstove or coal application, a telescopic rigid or flexible shield is required around the chimney. Except for installation in single and two-story family dwellings, the enclosure must have a fire resistance rating equal to or greater than that of the floor or roof assemblies through which they pass.
- Do not fill the 2" space around the chimney with insulation or any other material. Insulation placed in this area could cause adjacent combustibles to overheat.
- Self tapping screws are not required, but may be used to reinforce the connection and avoid accidental unlocking of chimney lengths.

### WARNING

**The clearance between the chimney and combustible material must not be less than 2", except where established by the support. Do not fill this area with insulation.**

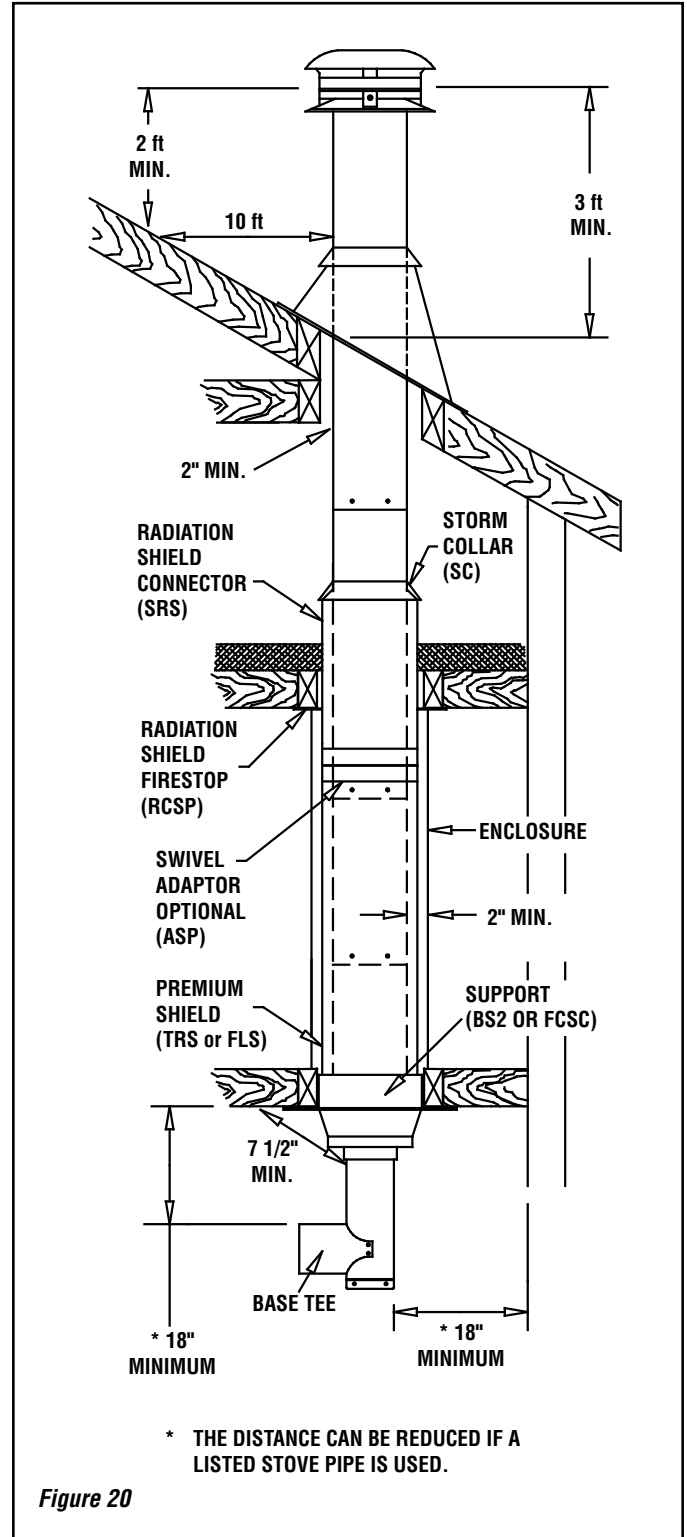

Figure 20

# INTERIOR STRAIGHT INSTALLATION WITH MULTIPLE FLOOR (CANADA)

Locate the chimney in a convenient place as near as possible to the appliance outlet.

Cut and frame the holes in the floor, ceiling and roof where the chimney will pass.

**Note:** It is important to follow the cutting dimensions for the floor openings prescribed in this manual. This way, the holes left by the folded positioning tab of the firestop (FS+ or AFRS) will be blocked by the ceiling.

CHIMNEY SIZE	HOLE SIZE	
	FINISH SUPPORT (FCSC) or (BS2)	RADIATION SHIELD* & ROOF
5"	12-1/8" x 12-1/8"	11-3/8" x 11-3/8"
6"	12-1/8" x 12-1/8"	12-3/8" x 12-3/8"
7"	14-3/8" x 14-3/8"	13-3/8" x 13-3/8"
8"	14-3/8" x 14-3/8"	14-3/8" x 14-3/8"
10"	---	16-3/8" x 16-3/8"

**Table 7** \* For sloping roofs see size table 3 on page 3

From below push the finish support into the framed hole. Nail the support to the framed box using (12) - 3" spiral nails (see figure 21).

If you are venting a Factory built fireplace or an oil or gas burning appliance please refer to installation notes #2 (on page 11) for guidelines on the use of the shields.

## FOR UNENCLOSED INSTALLATION OR VENTING OF OIL OR GAS APPLIANCES:

Refer to interior installation on a furnace and water heater guideline (page 19).

## FOR ENCLOSED INSTALLATION (6", 7", 8" dia. only) (woodstove or coal burning appliance):

- Lock the first chimney length into the support with the male coupling on top.
- Slide a Telescopic Rigid shield (TRS) on top of that length all the way to the bottom.

Stack the next chimney length on the first length. Be sure that the male and female threads are not in line when putting the lengths together. Turn the chimney clockwise to lock it in place. You may add a 1/2in stainless steel self tapping screw to prevent accidental unlocking.

Continue installing until the required chimney reached the attic level.

- At the ceiling level, install a Radiation Shield Connector (SRS) and a Radiation Shield Firestop (RCSP) on the chimney (figure 23).

Slide the Radiation Shield Connector down until the bottom of the insulated tube passes just through the Radiation Shield Firestop as shown in figure 4. Adjust the height until a min (1") of the Radiation Shield Connector passes through the firestop below.

Once you are satisfied with positioning of the Radiation Shield Connector, passes through the firestop below, Fix it to the chimney from the attic side using 3 self-tapping screws.

The Telescopic Shield is then slid upwards to the ceiling and attached to the bottom of the Radiation Shield Connector using 3 self-tapping screws.

### In the attic:

- If the chimney is not enclosed in the attic, a storm collar (SC+) must be install on top of radiation Shield to prevent any loose insulation from falling in the area between the chimney and the support.
- If the chimney is to be enclosed within the attic, continue installed chimney sections up through the roof opening. Lower another Telescopic Shield through the roof opening down onto the Radiation

Shield Connector. Adjust the height of the shield's tube so it terminates just above the roof opening but under the flashing. Once satisfied with positioning, secure both ends of the shield using self-tapping screws.

## ROOF FLASHING INSTALLATION

Put the roof flashing in place. Seal the joint between the roof and the flashing with roofing pitch.

For sloping roofs, place the flashing under the upper shingles and on top of the lower shingles.

Nail the flashing to the roof using roofing nails.

Place the storm collar over the chimney and the flashing. Tighten it with the bolt supplied making sure the joint is properly caulked (see figure 24).

Fit the rain cap to the top of the chimney. Turn it clockwise to lock it in place.

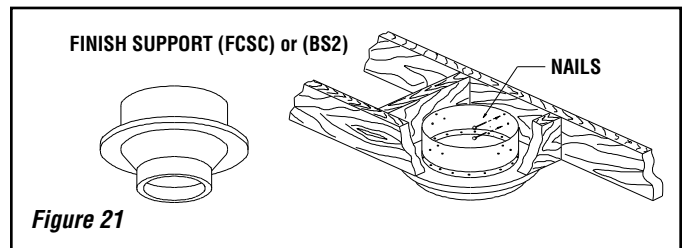

**Figure 21**

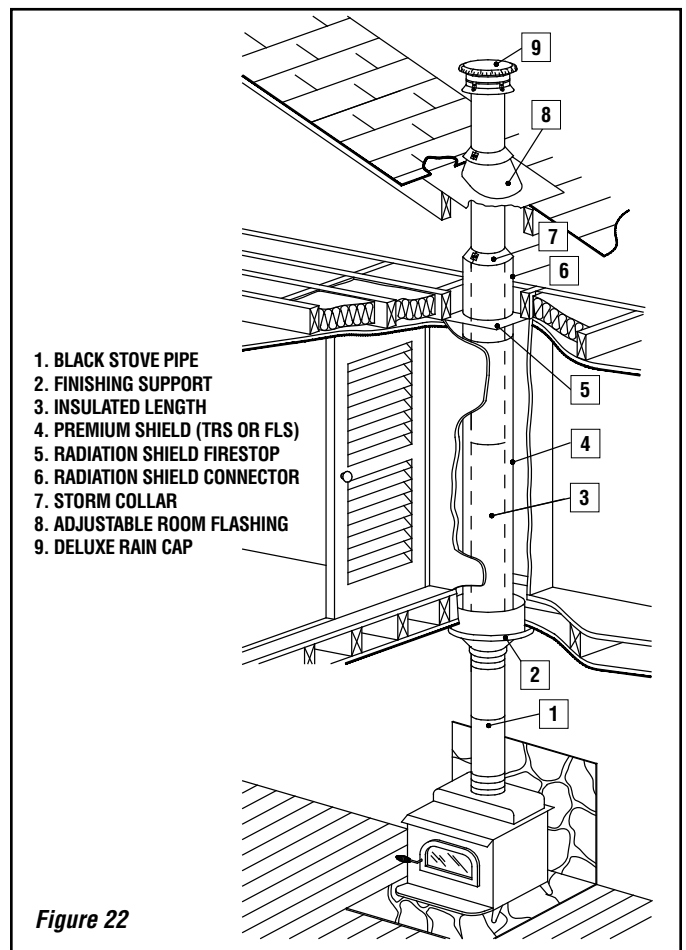

**Figure 22**

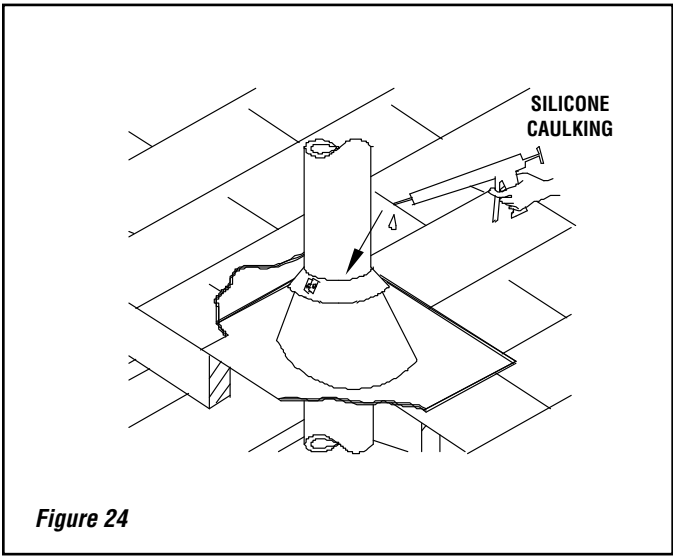
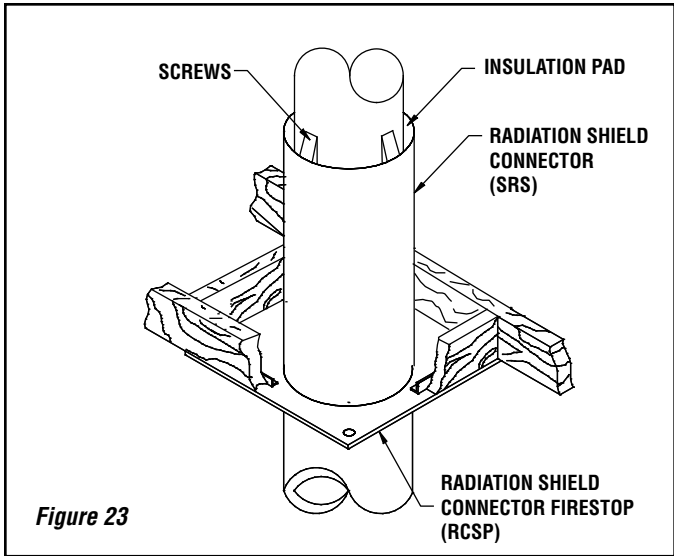

# 2

## INTERIOR INSTALLATION WITH CATHEDRAL CEILING (CANADA)

### A - CATHEDRAL SUPPORT (CSC)

This support is designed to be used in rooms with cathedral ceilings (no attic space between the ceiling and the roof). If the support is used as a regular floor support, follow the instructions for the finish support FCSC on [page 12](#).



**Step 1.** Situate the chimney in a convenient location as near as possible to the appliance outlet. Cut and frame a hole in the roof for the support. The sides of this hole must be vertical ([figure 25](#)) (see [table 3](#) on [page 3](#)).

**Step 2.** From above, place the support in the opening. Lower it to a convenient height.

**Note:** The cone portion of the support must extend below the ceiling. The minimum horizontal distance between the single wall stove pipe and the ceiling is 18".

Using a level, make sure the support is vertical. If the support extends above the roof, cut it flush with the top of the roof. Nail the support to the framed opening using (12)-3" spiral nails ([figure 26](#)).

TO CONTINUE INSTALLATION SEE PREVIOUS STEP 3 ON PAGE 12 .

### B - SQUARE SUPPORT (CSBC) AND ADJUSTABLE SQUARE SUPPORT (PPS)

This support is similar in application and installation as the cathedral support (CSC). Install it using the instructions above (refer to [figure 27](#) for visual references).

The adjustable square support requires an opening of 12" x 12" up to 12" x 22-1/2" in the ceiling (see [figure 28](#)).

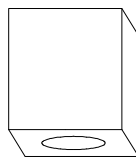

CSBC

### SUPPORT EXTENSION (CSBX) (For square support only)

Steep pitched cathedral ceilings may require the use of a square support extension (CSBX). This piece fits down inside the square support and can be adjusted to increase the support's length by up to 16".

The extension is attached to the support using the eight metal screws provided. Be sure there is at least a 2" overlap where the extension joins the support.

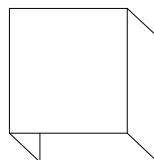

CSBX

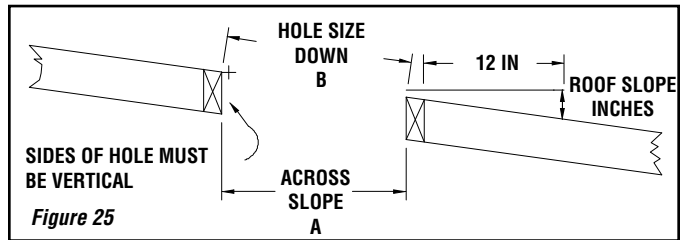

Figure 25

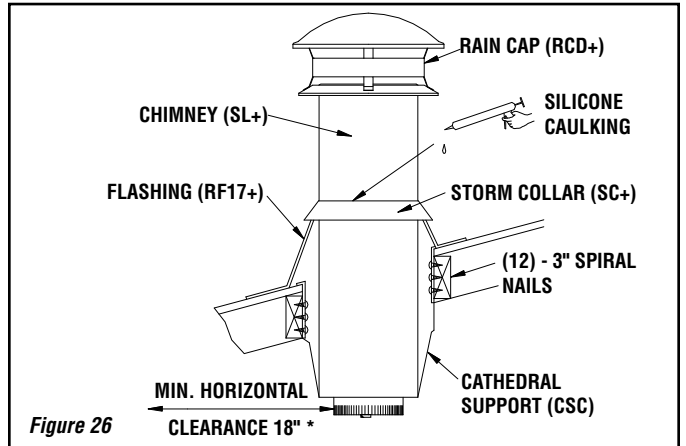

Figure 26

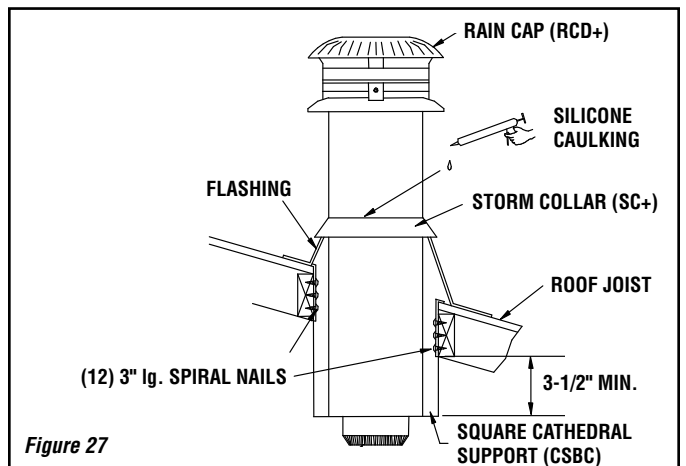

Figure 27

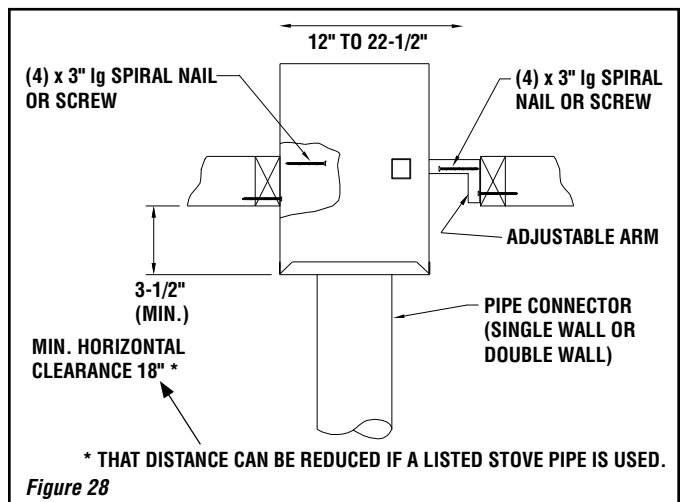

Figure 28



# 3

## OFFSET DEVIATION (CANADA)

### OFFSET CHIMNEY (CANADA)

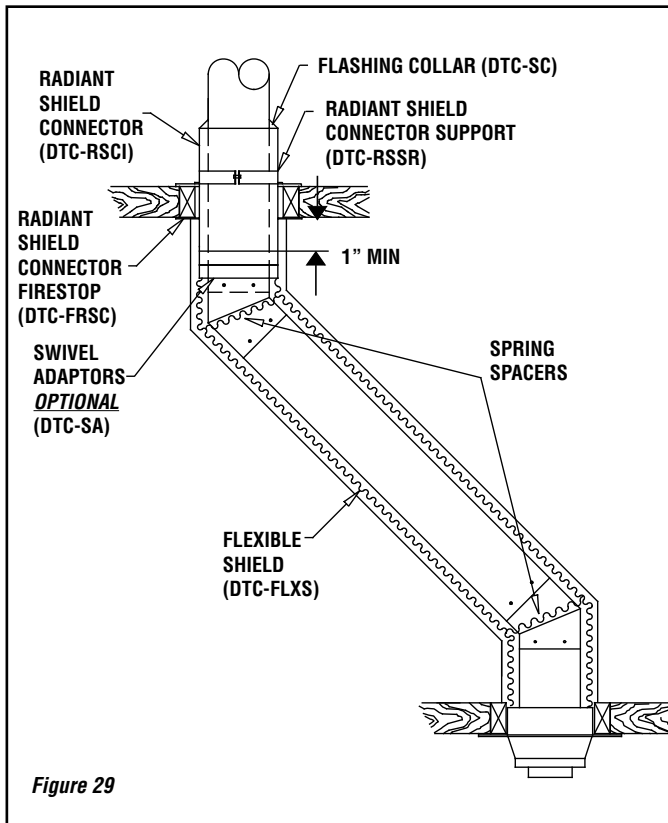

Figure 29

If it is necessary to offset the chimney in order for it to pass through an upstairs cupboard or to clear a joist, do this by using 15°, 30° or 45° insulated elbows. A maximum of two offsets (4 elbows in all) is allowed in a chimney.

The minimum chimney height when using 15° offsets is 10'.

The minimum chimney height when using 30° offsets is 15'.

The maximum length of unsupported offset chimney is 6'. If the offset chimney is longer than 6', then it must be supported at 6' intervals using an offset support (PSO+) or wall band (WB). Or if a Premium Shield is used then a Radiation Shield Connector (RSC) must be installed in the offset portion and attach to trusses with (2) two plumbers straps.

### INSTALLATION INSTRUCTIONS

**If you are venting a Factory built fireplace or an oil or gas burning appliance please refer to installation notes #2 (on page 12) for guidelines on the use of the Premium shields.**

#### For Unenclosed installation or venting of oil or gas appliances:

Put the first chimney length in the support. Turn it clockwise to lock it in place (see Figure 10 in USA section for reference).

**Note: the male coupling must be on top.**

Stack the next chimney length on the first length. Be sure that the male and female threads are not in line when putting the lengths together. Turn the chimney clockwise to lock it in place. You may add a 1/2" stainless steel self tapping screw to prevent accidental unlocking. When you reach the height at which the elbow will be install:

- Step 1.** Install the insulated offset elbow on the vertical chimney length. Turn it in the required direction and fasten it to the chimney with the (4)-1/2" metal screws provided.
- Step 2.** Place the required offset chimney length (see chart below) on the elbow. Turn it clockwise to lock it in place.
- Step 3.** Use another elbow to turn the chimney vertically. Again secure the elbow to the chimney length using the (4)-1/2" metal screws.

#### For Enclosed installation (6", 7", and 8" dia. only) (woodstove or coal burning appliance):

- Place the first chimney length on a flat surface with the male coupling on top.
- Slide a flexible shield (FLS) on top of that length all the way to the bottom.
- Attach the flexible shield to the section using 3 x 1/2" stainless steel self tapping screws.
- Slide this assembly in the support and turn clockwise to lock it in place.
- At the ceiling level from the top, install a Radiation Shield Connector (RSC) and a Radiation Shield Support (RSSR) attach but not tighten together yet (see Figure 31).
- Slide the Radiation Shield Connector down until the bottom of the insulated tube exceed the bottom of ceiling.

Adjust the height until a min (1") of Radiation Shield Connector exceed the bottom of ceiling (see Figure 29).

Stack the next chimney length on the first length. Be sure that the male and female threads are not in line when putting the lengths together. Turn the chimney clockwise to lock it in place. You may add a 1/2" stainless steel self tapping screw to prevent accidental unlocking.

When you reach the height at which the elbow will be install:

- Step 1.** Install the insulated offset elbow on the vertical chimney length. Turn it in the required direction and fasten it to the chimney with the (4)-1/2" metal screws provided.
- Step 2.** Place the required offset chimney length (see table 8) on the elbow. Turn it clockwise to lock it in place.
- Step 3.** Use another elbow to turn the chimney vertically. Again secure the elbow to the chimney length using the (4)-1/2" metal screws.

**Attach a spacer spring around the chimney at each elbow to help keep the flexible shield centered.** (See figure 29) Slide the flexible shield up the chimney and attach it below the ceiling to the Support Radiation Shield using 3 self tapping metal screws. If you are limited in space to screw, install a Swivel Adaptor (ASP) (figure 29) below the Shield Connector (RSC) and one on the top end of the flexible shield.

#### In the attic:

- Fix the radiation shield to the chimney and tight the support collar.
- If the chimney is not enclosed in the attic, a storm collar (SC+) must be install on top of Radiation Shield to prevent any loose insulation from falling in the area between the chimney and the support.
- If the chimney is to be enclosed within the attic, continue installed chimney sections up through the roof opening. Lower another Telescopic Shield through the roof opening terminates just above the roof opening but under the flashing. Once satisfied with positioning, secure both ends of the shield using self-tapping screws.

# 3

## OFFSET DEVIATION (CONT'D) (CANADA)

### ⚠ WARNING

A support must always be installed right above each offset (two elbows) to support the chimney above the offset.

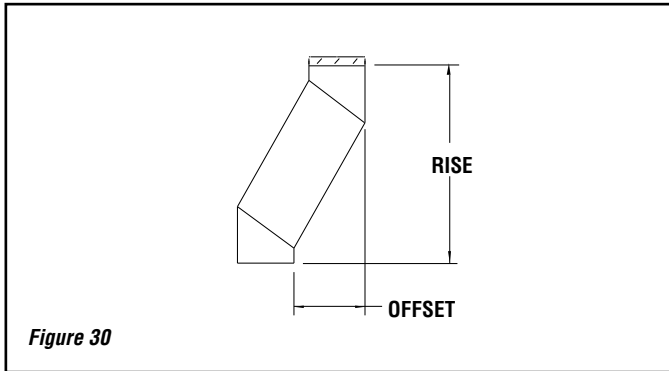

Figure 30

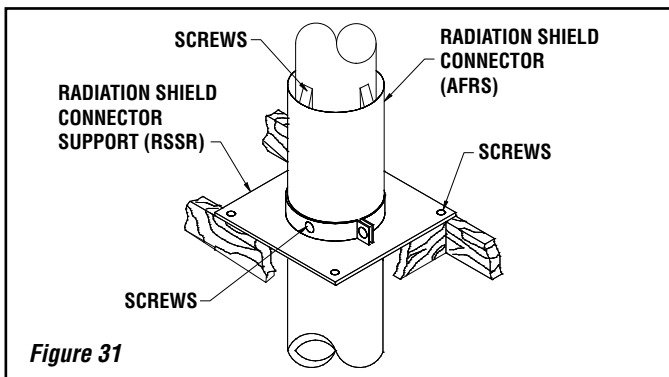

Figure 31

Install the remaining chimney as described in the instructions for the Interior Straight installation.

### INSTALLATION CALCULATIONS

Determine the offset required in view of the obstacles that must be avoided (see figure 30). Refer to table 8 below to determine the elbows required as well as the insulated length needed.

### OFFSET & RISE CHART MODEL HT6103+ (5" @ 10")

ANGLE	DIA.	INCHES	ONE LENGTH BETWEEN ELBOWS						TWO LENGTHS BETWEEN ELBOWS					
			8	12	18	24	36	48	8 & 48	12 & 48	18 & 48	24 & 48	36 & 48	48 & 48
15°	5" @ 10"	Offset	3-5/16	4-5/16	5-7/8	7-7/16	10-1/2	13-5/8	15-3/8	16-7/16	18	19-1/2	22-5/8	25-3/4
		Rise	15-11/16	19-9/16	25-3/8	31-3/16	42-3/4	54-3/8	60-15/16	64-13/16	70-9/16	76-3/8	87	99-9/16
30°	5" @ 10"	Offset	7-7/16	9-7/16	12-7/16	15-7/16	21-7/16	27-7/16	30-13/16	32-13/16	35-13/16	38-13/16	44-13/16	50-13/16
		Rise	20	23-1/2	28-11/16	33-7/8	44-1/4	54-11/16	60-9/16	64	69-1/4	74-7/16	84-13/16	95-1/4
45°	5" @ 10"	Offset	10-5/16	13-3/16	17-3/8	21-5/8	30-1/8	38-5/8	43-7/16	46-1/4	50-1/2	54-3/4	63-1/4	71-11/16
		Rise	17-13/16	20-5/8	24-7/8	29-1/8	37-5/8	46-1/8	50-15/16	53-3/4	58	62-1/4	70-3/4	79-3/16

Table 8

### ROOF SUPPORT (PST+) (CANADA)

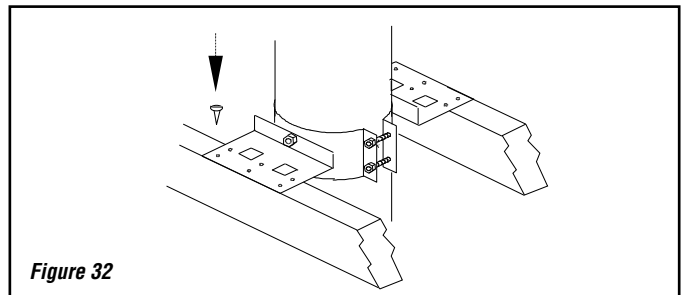

Figure 32

The roof support has three possible uses:

It may be used to support a chimney from the roof. It adjusts to any roof pitch.

It may be used on a floor, ceiling or roof above an offset to support the chimney above the offset.

It may be used on a floor, ceiling or roof as a supplementary support when the chimney height exceeds that of the primary support. (See maximum length height supported, page 3).

### INSTALLATION INSTRUCTIONS

With the chimney extending through the hole in the roof, ceiling or floor and the radiation shield in place, proceed as follows (Refer to figure 13B for visual references):

- Step 1.** Assemble the support collar to fit your chimney diameter, as described on the instruction sheet supplied with the support.
- Step 2.** Slip the support down over the stainless steel chimney until its brackets rest on the roof or floor. Tighten the collar around the chimney, then secure it by screwing the four 1/2" metal screws (supplied) through the holes located on each side of the collar bolts and into the chimney (Figure 32).
- Step 3.** Center the chimney and nail or screw the support to the roof or floor using (8) - 2-1/2" nails or (8) N°8 - 1-1/4" wood screws. (figure 13A).

# 4

## EXTERIOR INSTALLATION (CANADA)

### TEE & WALL SUPPORT (CANADA)

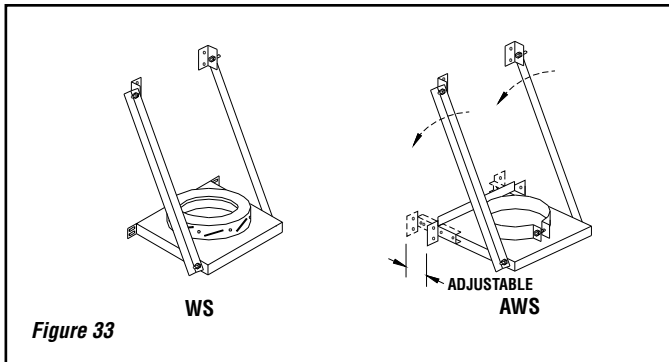

Figure 33

Three supports are available, an adjustable with collar (AWS) and a non-adjustable with coupling (WS).

### INSTALLATION NOTES

If possible, install an interior chimney as it will provide better performance than an exterior chimney. In areas with continuous temperatures below -18°C (0°F), the use of an exterior chimney may result in operating problems such as poor draft, excessive condensation of combustion products and rapid accumulation of creosote when connected to a wood burning appliance. If you do install an exterior chimney, we recommend that you enclose it using an insulated enclosure.

1. The chimney may be enclosed or unenclosed. **If enclosed at 2" clearance all around the chimney on a wood stove application, a Premium shield must be installed around the chimney (Figure 36).**
2. Maintain 2" clearance to combustible materials. Do not fill the 2" space around the chimney with insulation or any other material.
3. A wall band must be used to secure the chimney to the wall. Maximum distance between wall bands is 8 feet.
4. The minimum length of chimney extending past the inside wall is 5 inches.
5. The maximum length of chimney extending past the inside wall is 24 inches.
6. The distance between the stove pipe and a parallel combustible wall or ceiling must not be less than 18". The distance between the horizontal stove pipe and the unshielded vertical wall through which it passes must not be less than 7 inches.
7. If an exterior installation is to be enclosed, allow for access to base of tee to facilitate required cleaning.
8. **The minimum distance between the bottom of the support and any horizontal combustible (including the ground) is 6". This distance can be reduced to 2 inches by using an insulated tee cap (IC) in conjunction with a (AWS) wall support.**
9. The adjustable support (AWS) may only be installed with an insulated tee cap (IC).

### INSTALLATION INSTRUCTIONS STEPS

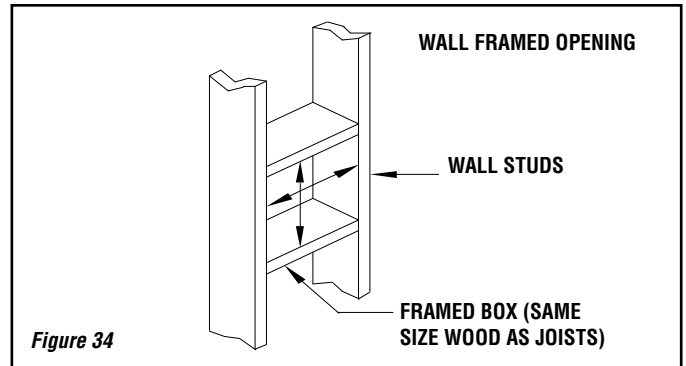

Figure 34

Determine where the chimney will pass through the wall.

- For concrete walls cut a hole slightly larger than the chimney.
- For combustible walls cut and frame a hole 4" larger than the chimney, midway between the wall studs (see table below for sizing).

Normally wall studs are placed at 16" centers. With the hole midway between them, the support will fasten to these studs and thus ensure a strong attachment to the wall. (see Figure 34).

CHIMNEY SIZE	HOLE SIZE	
	COMBUSTIBLE	CONCRETE
5"	11-3/8" x 11-3/8"	7-3/4"
6"	12-3/8" x 12-3/8"	8-3/4"
7"	13-3/8" x 13-3/8"	9-3/4"
8"	14-3/8" x 14-3/8"	10-3/4"
10"	16-3/8" x 16-3/8"	12-3/4"

Table 9

Wood walls: from outside, put the square wall thimble (WRS+) in the hole. Nail in place using (4) 2" nails or 1" screws. This wall thimble is adjustable from 7" to 12". From inside, wrap the insulation pad around the tube of the square wall thimble previously installed. Place the metal sheet around the insulation pad and close it by joining the staples at each end of the metal sheet together. Make sure the gap is completely filled in from inside to outside (cut insulation pad to proper length).

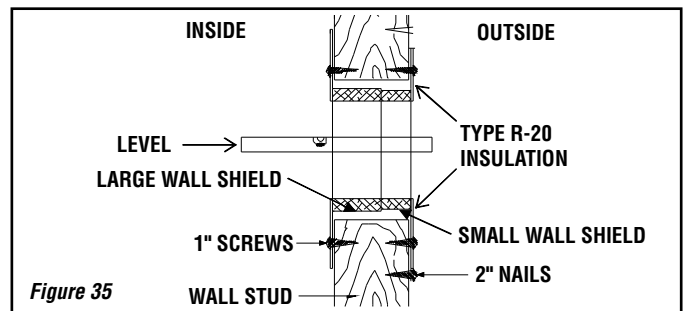

Figure 35

# 4

## EXTERIOR INSTALLATION (CONT'D) (CANADA)

Slide the large wall shield over the small wall shield. Using a level make sure that the hole for the chimney to pass through is horizontal. Screw the inner thimble in place with the provided screws (see **Figure 35**).

Note: The cavity surrounding the wall thimble must be filled with type R-20 insulation (see **Figure 35**).

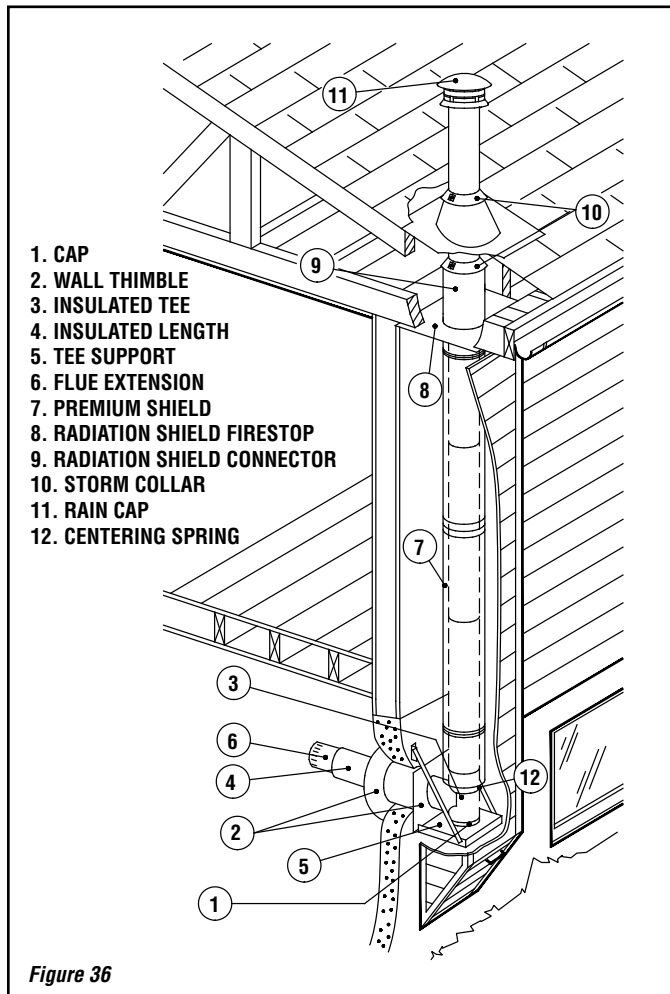

Figure 36

Attach the clean-out cap to the support's flue extension using the three metal screws provided. Make sure that the screws have pierced through the flue extension. The cap is in the box with the insulated tee. If an insulated tee cap is used, twist lock the tee cap to the tee (adjustable support AWS only).

The minimum length of insulated chimney required to pass through the wall will be thickness plus 7". The insulated chimney must extend at least 5" into the room beyond the finished wall. Insert this chimney length in the side entry of the insulated tee. Turn it clockwise to lock it in place. Seal this joint by wrapping it with the aluminium tape supplied with the tee.

Mount the insulated tee on the support so that the chimney length which will go through the wall is perpendicular to the side of the support that will fasten to the wall.

This step will require 2 people: (See **figure 19**)

Insert the chimney length of this tee-support assembly into the hole in the wall. Using a level, ensure the tee is vertical, then attach the support to the wall using (8) N°. 10 x 1 - 1/4" wood screws or 4" spiral nails.

NOTE: To provide sufficient strength, the nails must be driven into the wall studs. For concrete walls, the support should be attached using (8) 1/4" x 2" lag bolts.

Attach the flue extension to the horizontal chimney length using the three metal screws provided.

Stack a chimney length on top of the tee. Turn it clockwise to lock it in place.

### **FOR UNENCLOSED INSTALLATION OR VENTING OF OIL OR GAS APPLIANCES:**

Continue until the required chimney height is reached.

NOTE: At 8' intervals, attach the chimney to the wall using a wall band (WB).

If the chimney passes through the roof, cut a hole large enough to provide 2" clearance between the chimney and the roof. For pitch roof, see **table 3** on **page 3**.

### **FOR ENCLOSED INSTALLATION AT 2" FROM COMBUSTIBLES (Woodstove or coal burning appliance only):**

Put a first chimney length on the Tee. Turn it clockwise to lock it in place (see **figure 22**).

**Note: the male coupling must be on top.**

**Slide a Radiation Shield Connector on that first chimney section and fasten it using 3 self tapping metal screws.**

Stack the next chimney length on the first length. Be sure that the male and female threads are not in line when putting the lengths together. Turn the chimney clockwise to lock it in place. You may add a 1/2in stainless steel self tapping screw to prevent accidental unlocking.

Slide a telescopic rigid shield over that section and attach it to the radiation shield connector.

Continue installing chimney sections up through the roof opening. Pull the telescopic shield tube up to the roof opening Adjust the length of the shield tube so that it terminates just above the roof opening but under the flashing. Screw the sections of the shield together using 3 self tapping screws per joint.

**TO CONTINUE, SEE ROOF FLASHING INSTALLATION, ON PAGE 12.**

# 5

## INTERIOR INSTALLATION ON A FURNACE AND WATER HEATER (USA & CANADA)

**Step 1.** Locate the chimney in a convenient place as near as possible to the appliance outlet. Cut and frame the holes in the floor, ceiling and roof where the chimney will pass.

**NOTE:** It is important to follow the cutting dimensions for the floor openings prescribed in this manual. This way, the holes left by the folded positioning tab of the firestop (FS+ or AFRS) will be blocked by the ceiling.

Chimney Size	Hole size
5"	12-1/8" x 12-1/8"
6"	12-1/8" x 12-1/8"
7"	14-3/8" x 14-3/8"
8"	14-3/8" x 14-3/8"
10"	14-3/8" x 14-3/8"

*Table 10*

**Step 2.** From below push the support into the framed hole. Nail the support to the framed box using (12) 3" spiral nails (see **Figure 37**).

**Step 3.** Put this first chimney length in the support. Turn it clockwise to lock it in place.

**NOTE:** The male coupling must be on top.

**Step 4.** From below, install a firestop (FS+) in each floor through which the chimney passes (see **Figure 38**).

**Step 5.** Stack the next chimney length on the first length. Be sure that the male and female threads are not in line when putting the lengths together. Turn the chimney clockwise to lock it in place. Continue until the required chimney height is reached.

**Step 6.** At the attic level, install a firestop (FS+), from below and an attic radiation shield (AFRS) from above (see **Figure 39**).

**Step 7.** U.S. ONLY: Install the roof radiation shields in the roof joists. These shields consist of four metal plates. Nail one plate to each side of the joist using (2) 2-1/2" nails.

**Step 8.** Put the roof flashing in place. Seal the joint between the roof and the flashing with roofing pitch.

For sloping roofs, place the flashing under the upper shingles and on top of the lower shingles.

Nail the flashing to the roof using roofing nails.

**Step 9.** Place the storm collar over the chimney and the flashing. Tighten it with the bolt supplied making sure the joint is properly caulked (see **Figure 40**).

Fit the rain cap to the top of the chimney. Turn it clockwise to lock it in place.

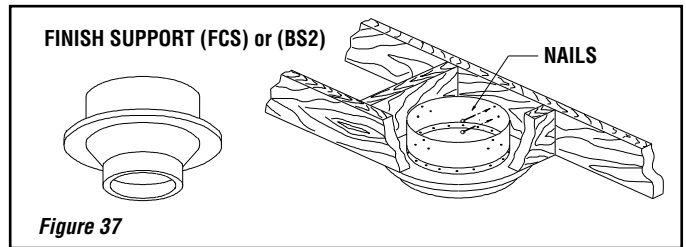

*Figure 37*

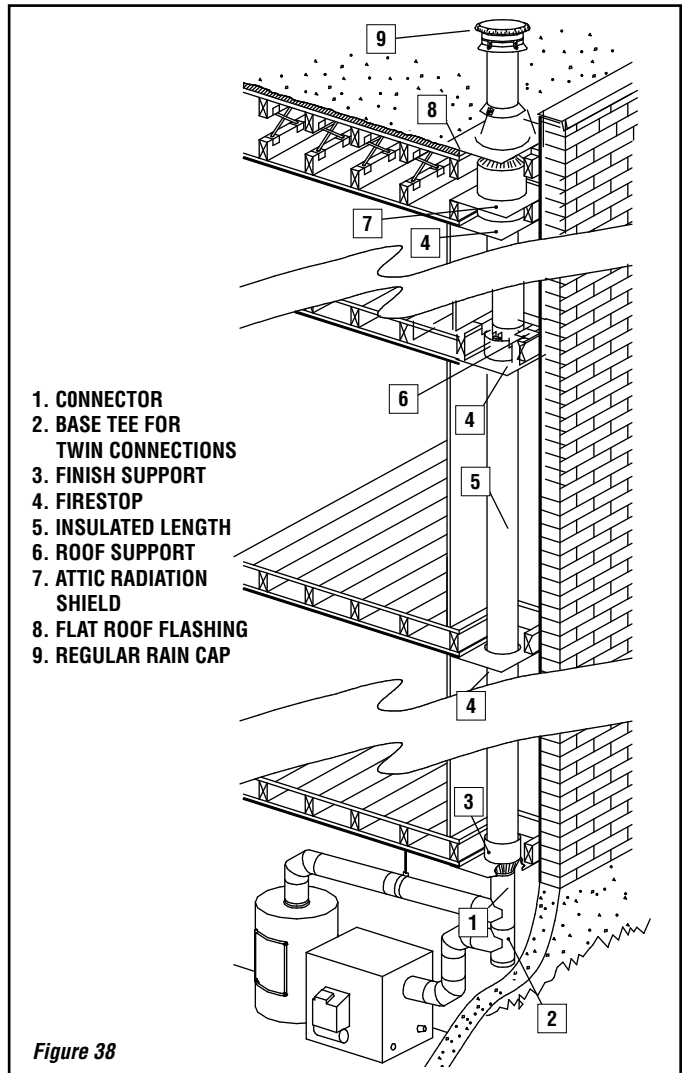

*Figure 38*

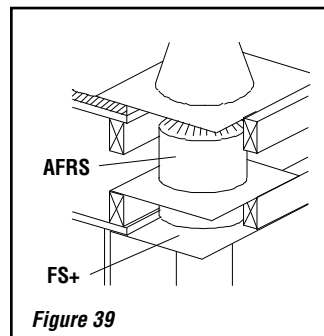

*Figure 39*

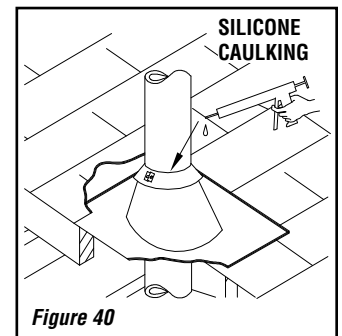

*Figure 40*



## SPECIALIZED COMPONENTS (USA & CANADA)

### ANCHOR PLATE (SP)

This support is used on a masonry fireplace or on top of a furnace to provide a positive connection to the chimney. It is not to be used in contact with any combustible material, such as on a wood floor.

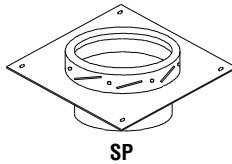

### INSTALLATION INSTRUCTIONS

Once the appliance is installed, bolt the anchor plate to it. Install the chimney according to the installation instructions for the finish support (FCSC).

### FACTORY-BUILT FIREPLACES

For chimneys installed on factory-built fireplaces, follow the installation instructions accompanying the fireplace.

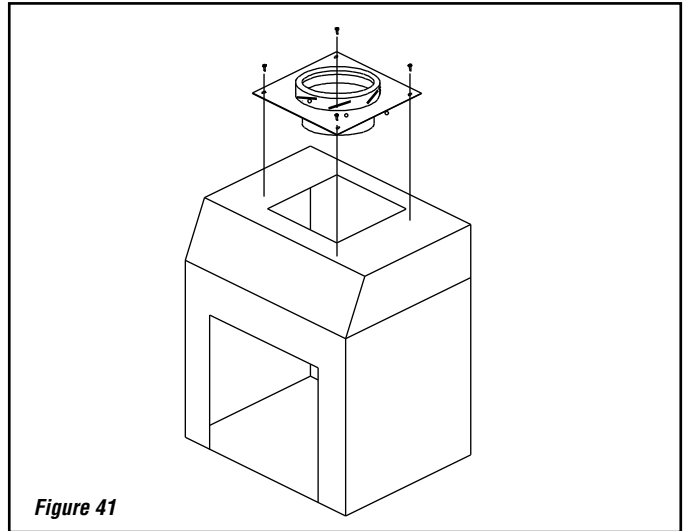

Figure 41

### INSULATED WALL RADIATION SHIELDS

These are used only with wood-burning fireplaces which have been certified for use with the HT6103+.

### INSULATED RADIATION SHIELD (IWRs)

It must be used in combination with an attic radiation shield (AFRS) when passing through an attic. This component provides a 2" safety clearance to combustible materials surrounding the chimney.

### ANGLED INSULATED RADIATION SHIELD (IWRs30/IWRs45)

It has been designed for use when a chimney passes through a wall at an angle. (See *figure 14* for application).

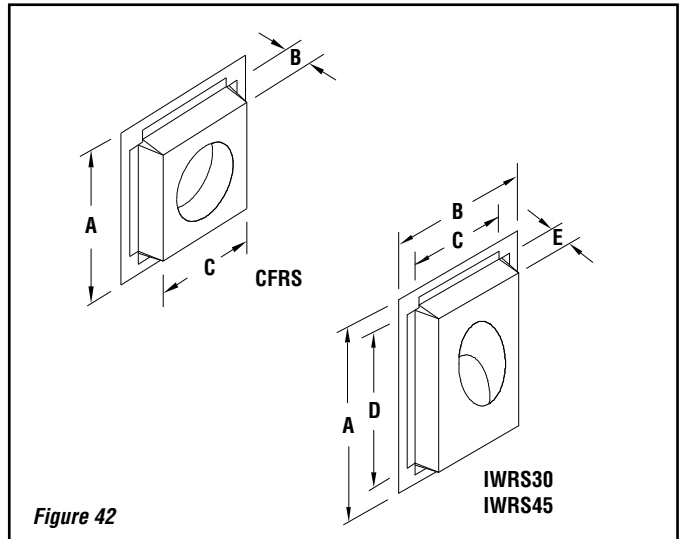

Figure 42

Ø INT.	FRAMING SIZE								
	CFRS			IWRs30			IWRs45 (CANADA ONLY)		
	7"	8"	10"	7"	8"	10"	7"	8"	10"
A	16	16	18	37-3/4	39-3/4	45-5/16	26-5/8	28	30-1/2
B	3	3	3	16-5/8	17-5/8	19-3/8	16-5/8	17-5/8	19-3/8
C	13	13	5	12-5/8	13-5/8	15-3/8	12-1/8	13-1/2	14-7/8
D	--	--	--	33-3/4	35-3/4	39-1/4	22-1/8	23-1/2	26
E	--	--	--	3	3	3	3	3	3

Table 11



# SECURITY CHIMNEYS INTERNATIONAL, LTD. RESIDENTIAL CHIMNEY & VENTING PRODUCT LIMITED LIFETIME WARRANTY

## THE WARRANTY

This Security Chimneys International, Ltd. (SCIL) Limited Lifetime Warranty warrants your residential vent and/or chimney system to be free from defects in material and workmanship at the time of manufacture. This Limited Lifetime Warranty includes all components and fittings, except termination caps and Secure Black™ SW single wall black stove pipe. After installation, if covered components manufactured by SCIL are found to be defective in materials or workmanship during the Limited Lifetime Warranty period and while the Product remains at the site of the original installation, SCIL will, at its option, replace the covered components. SCIL reserves the right to replace covered components with an equivalent product and the replacement must be carried out in accordance with SCIL's recommendations. If replacement is not commercially practical, SCIL will, at its option, refund the purchase price or wholesale price of the SCIL product, whichever is applicable. THERE ARE EXCLUSIONS AND LIMITATIONS to this Limited Lifetime Warranty as described herein.

## COVERAGE COMMENCEMENT DATE

Warranty coverage begins on the date of installation. In the case of new home construction, warranty coverage begins on the date of first occupancy of the dwelling or six months after the sale of the Product by an independent SCIL dealer/distributor, whichever occurs earlier. The warranty shall commence no later than 24 months following the date of product shipment from SCIL, regardless of the installation or occupancy date.

## EXCLUSIONS AND LIMITATIONS

This Limited Lifetime Warranty applies only if the Product is installed in the United States or Canada and only if used for the application for which it was designed and intended. The Product must be maintained in accordance with the printed instructions accompanying the Product and in compliance with all applicable installation and building codes and good trade practices.

This warranty is transferable. The Product must be purchased through a listed supplier of SCIL and proof of purchase must be provided. SCIL will be responsible for the replacement of the residential vent and/or chimney system considered to be defective for the following periods:

**Termination Caps & Secure Black SW Stove Pipe** – Replacement at no charge for 5 years from the date of installation, excluding labor

**Components and fittings** (excludes termination caps and Secure Black SW) –

Year 1-15 – Replacement of all components and fittings (a labor allowance may apply to a maximum of 300 \$ \* certain conditions apply).

Year 16 + – Replacement at 50% off of the prevailing list price in effect at the time of replacement (No labor allowance applies).

\*Labor Allowance Conditions: Any Warranty replacement work must be performed by a Professional Installer.

SCIL will not be responsible for: (a) damages caused by normal wear and tear, corrosion from salt air, accident, riot, fire, flood or acts of God; (b) damages caused by abuse, negligence, misuse, or unauthorized alteration or repair of the Product affecting its stability or performance. (The Product must be subject to normal use with approved fuels listed in the Operation Manual provided with the product. Where applicable, fuel products with abnormal burning characteristics, including but not limited to fuel such as driftwood, plywood and wood products using a binder may burn at excessive temperatures and may cause damage to the Product or may cause it to function improperly; (c) damages caused by failing to provide proper maintenance and service in accordance with the instructions provided with the Product; (d) damages, repairs or inefficiency resulting from faulty installation or application of the Product.

This Limited Lifetime Warranty covers only parts as provided herein. SCIL's entire liability is limited to the purchase price of this product. In no case shall SCIL be responsible for materials, components or construction which are not manufactured or supplied by SCIL or for the labor necessary to install, repair or remove such materials, components or construction. Additional utility bills incurred due to any malfunction or defect in equipment are not covered by this Limited Lifetime Warranty. All replacement or repair components will be shipped F.O.B. from the nearest stocking SCIL factory.

## LIMITATION ON LIABILITY

It is expressly agreed and understood that SCIL's sole obligation and the purchaser's exclusive remedy under this warranty, under any other warranty, expressed or implied, or in contract, tort or otherwise, shall be limited to replacement, repair, or refund, as specified herein.

In no event shall SCIL be liable for any incidental or consequential damages caused by defects in the Product, whether such damage occurs or is discovered before or after replacement or repair, and whether such damage is caused by SCIL's negligence. SCIL has not made and does not make any representation or warranty of fitness for a particular use or purpose, and there is no implied condition of fitness for a particular use or purpose.

SCIL makes no expressed warranties except as stated in this Limited Lifetime Warranty. The duration of any implied warranty is limited to the duration of this expressed warranty.

No one is authorized to change this Limited Lifetime Warranty or to create for SCIL any other obligation or liability in connection with the Product. Some states and provinces do not allow the exclusion or limitation of incidental or consequential damages, so the above limitations or exclusions may not apply to you. The provisions of this Limited Lifetime Warranty are in addition to and not a modification of or subtraction from any statutory warranties and other rights and remedies provided by law.

## INVESTIGATION OF CLAIMS AGAINST WARRANTY

SCIL reserves the right to investigate any and all claims against this Limited Lifetime Warranty and to decide, in its sole discretion, upon the method of settlement.

To receive the benefits and advantages described in this Limited Lifetime Warranty, the appliance must be installed and repaired by a licensed contractor approved by SCIL. Contact SCIL at the address provided herein to obtain a listing of approved dealers/distributors. **SCIL shall in no event be responsible for any warranty work done by a contractor that is not approved without first obtaining SCIL's prior written consent.**

## HOW TO REGISTER A CLAIM AGAINST WARRANTY

In order for any claim under this warranty to be valid, you must contact the SCIL dealer/distributor from which you purchased the product. If you cannot locate the dealer/distributor, then you must notify SCIL in writing. SCIL must be notified of the claimed defect in writing within 90 days of the date of failure. Notices should be directed to the SCIL Warranty Department at 2125 Monterey Street, Laval, QC H7L 3T6.

## WARRANTY

This product has a limited lifetime warranty. Please read the warranty to be familiar with its coverage.

Retain this manual. File it with your other documents for future reference.

## PRODUCT REFERENCE INFORMATION

Please contact Oliver Macleod® for the phone number of your nearest Oliver Macleod dealer who will answer your questions or address your concerns.

Normally, all parts should be ordered through your Oliver Macleod distributor or dealer. Parts will be shipped at prevailing prices at time of order.

When ordering repair parts, always give the following information:

1. The model number of the vent system.
2. The part number.
3. The description of the part.
4. The quantity required.
5. The installation date of the chimney system.

If you encounter any problems or have any questions concerning the installation or application of this system, please contact your dealer.

### SECURITY CHIMNEYS INTERNATIONAL LIMITED

2125 Monterey street

Laval, Québec, Canada, H7L 3T6

(450) 973-9999

Visit us at [www.securitychimneys.com](http://www.securitychimneys.com)

---

Security Chimneys International Limited reserves the right to make changes at any time, without notice, in design, materials, specifications, prices. Consult your local distributor for chimney system code information.



Printed in Canada © 2010 SECURITY CHIMNEYS INTERNATIONAL

P/N 506128-14 Rev. N 06/2014

2125 Monterey Laval, Québec • Canada, H7L 3T6